



User Manual

JK7000

Muti-Channel Data Recorder

Ver.2.0

Changzhou Jinailian Electronic Technology Co., Ltd
No.C3,Building 22,New Impetus Pioneering Center,
No.1,Qingyang North Road,Tianning
District,Changzhou,JIANGSU,CN

TEL: 0086-519-85563477 E-mail: 5117jk17@163.com

<https://jinailian.en.alibaba.com> <http://www.jinko-tech.com/>

Content

One.Overview.....	1
Two. Function and characteristics.....	3
Three. Technical parameter.....	5
Four. Installation & wiring and structure.....	8
Five. Instrument operation and parameter setting.....	15
Six. Communication settings and protocols.....	36
Seven. Software Instructions.....	46

ONE.Overview

JK7000 touch data recorder is in our company in the accumulation of multi-channel temperature recorder on the basis of the experience, another masterpiece after 10 years, with its rich display, flexible operation and strong record, operation, control, management and powerful function, widely applicable to all walks of life. This product is to absorb the advantages of all kinds of domestic and foreign data recorder technology, microelectronic technology, communication technology, data storage and display of the latest application, is a complete function, convenient operation, accurate and reliable, cost-effective products.

This product is equipped with color LCD touch screen display. Can the current, voltage and resistance signals of various types, temperature, humidity, pressure, liquid level, flow rate and composition as well as force, torque, displacement etc. display, record, limit monitoring, report generation, data communication, signal transmission and flow accumulation function.

This product is mainly composed of touch screen, buttons, ARM microprocessor as the core board, the main power supply, external transmitter power supply, data acquisition board, signal output board, large capacity FLASH and other components:

Can be equipped with different types of intelligent data acquisition control board, according to the application requirements.

Built in large capacity FLASH, you can quickly through the U disk data will be dumped into the computer FLASH. Built in FLASH capacity of 70M or more to 2G bytes, 8 channel, if the record can be recorded for 10 seconds a record of 720 hours, the fastest one second record of all channels of data.

Digital display interface, bar chart display screen, real-time (History) curve screen, alarm data page.

History curve reading cursor function.

Basic error of measurement and display: $\pm 0.2\%$ F.S.

Parameters can be set multi-point alarm function.

TWO. Function and Characteristics

This product shows a large amount of information, user-friendly, simple operation, the following are the main features:

Using ARM microprocessor, can simultaneously achieve multi-channel (instrument host 80 or more channels) signal acquisition, recording, display and alarm;

Do not need pen and paper records, daily maintenance workload is very small, low operating costs;

Using high brightness touch color TFT LCD screen, CCFL backlight, clear screen; 70MB large capacity FLASH memory chip to store historical data, power loss will never lose data

Full isolation universal input \ can enter a variety of signals at the same time, no need to replace the module, set directly on the instrument;

Display a wide range of numerical values of engineering data can display 6 bit values: -999, 99~1999.99;

Parameters can be set to display the project number, engineering units, such as the cumulative flow function;

With red alarm display, while indicating the lower and upper limit, Upper limit alarm; 8 relay alarm output(customized);

High precision, basic error $\pm 0.2\%$ F·S;

The built-in GB2312 Chinese characters library, use Quanpin input method;

Support external micro printing, built-in printer, manual data and curve printing, automatic timing of data printing, to meet the needs of the user's site printing (customized products);

Standard USB2.0 interface. Keyboard and mouse can be used to facilitate the

operation, the output of historical data can be stored fast and conveniently;

Standard serial communication interface with optical isolation RS485 and RS232C and Ethernet support standard ModBus RTU communication protocol (optional function), in addition to supporting the company's data management software, it support other configuration software;

The switching power supply can be used in the AC power supply AC 85V~265V wide voltage range;

Provide transmitter DC 24V isolated distribution;

Through the EMCIII level, to ensure that the instrument works in the harsh environment normally.

THREE. Technical Parameter

3.1.Display

7 inch color TFT touch LCD digital display screen, bar picture, real-time (History) curve screen, alarm display screen a total of four basic images.

(8 channels containing integrated interface) basic error is less than $+ 0.2\%F * S$, digital display range -999.99~1999.99 measurement resolution: 1/120000, 24 bit AD converter

Real time curve recording interval of 1 second ~9999 seconds, corresponding to the entire screen curve time 30 seconds ~300 minutes to view the history curve from one second to 9999 seconds which can be set consistently.

3.2 Input signal

The input signal includes DC current, DC voltage, thermal resistance, thermocouple, remote pressure gauge , you can choose to use keyboard or touch screen to operate. Isolated universal input, without using jumper.

JK9000 Analog input specification		
Item		Content
Input type		Photoelectric relay scanning mode, full channel insulation input, balanced input
Mode input terminal shape		M3 Screw terminal
Measuring range	Voltage	0.01mV-100V F.S.(full range) ,Highest resolution 1 μ V
	Thermal resistance	Type: PT100
	Thermocouple	Type: K、J、E、T、R、S、B、N
	Humidity	Digital signal input (Switzerland Rotronic accuracy 0.8%) (domestic high accuracy 1.5%)
	Current	0.01mA-20.00mA
	Sampling rate	100ms (full channel)

Measuring accuracy	Temperature/ thermocouple	Types	Measuring temperature range (TS:measuring temperature)	Measuring accuracy	
		R	$0 \leq TS \leq 100^{\circ}\text{C}$	$\pm 5.2^{\circ}\text{C}$	
			$100 < TS \leq 300^{\circ}\text{C}$	$\pm 3.0^{\circ}\text{C}$	
			$300 < TS \leq 1600^{\circ}\text{C}$	$\pm (0.05\% \text{ of rdg.} + 2.0^{\circ}\text{C})$	
		S	$0 \leq TS \leq 100^{\circ}\text{C}$	$\pm 5.2^{\circ}\text{C}$	
			$100 < TS \leq 300^{\circ}\text{C}$	$\pm 3.0^{\circ}\text{C}$	
			$300 < TS \leq 1760^{\circ}\text{C}$	$\pm (0.05\% \text{ of rdg.} + 2.0^{\circ}\text{C})$	
		B	$400 \leq TS \leq 600^{\circ}\text{C}$	$\pm 3.5^{\circ}\text{C}$	
			$600 < TS \leq 1820^{\circ}\text{C}$	$\pm (0.05\% \text{ of rdg.} + 2.0^{\circ}\text{C})$	
		K	$-200 < TS \leq 0^{\circ}\text{C}$	$\pm (0.05\% \text{ of rdg.} + 2.0^{\circ}\text{C})$	
			$0^{\circ}\text{C} < TS \leq 1370^{\circ}\text{C}$	$\pm (0.5\% \text{ of rdg.} + 1.0^{\circ}\text{C})$	
		E	$-200 \leq TS \leq -100^{\circ}\text{C}$	$\pm (0.05\% \text{ of rdg.} + 2.0^{\circ}\text{C})$	
			$-100 < TS \leq 800^{\circ}\text{C}$	$\pm (0.05\% \text{ of rdg.} + 1.0^{\circ}\text{C})$	
		T	$-200 \leq TS \leq -100^{\circ}\text{C}$	$\pm (0.5\% \text{ of rdg.} + 1.5^{\circ}\text{C})$	
			$-100 < TS \leq 400^{\circ}\text{C}$	$\pm (0.1\% \text{ of rdg.} + 0.5^{\circ}\text{C})$	
		J	$-200 \leq TS \leq -100^{\circ}\text{C}$	$\pm 2.7^{\circ}\text{C}$	
			$-100 < TS \leq 100^{\circ}\text{C}$	$\pm 1.7^{\circ}\text{C}$	
			$100 < TS \leq 1100^{\circ}\text{C}$	$\pm (0.05\% \text{ of rdg.} + 1.0^{\circ}\text{C})$	
		N	$-200 \leq TS < 0^{\circ}\text{C}$	$\pm (0.1\% \text{ of rdg.} + 2.0^{\circ}\text{C})$	
			$0 \leq TS \leq 1300^{\circ}\text{C}$	$\pm (0.1\% \text{ of rdg.} + 1.0^{\circ}\text{C})$	
		Standard contact compensation accuracy			$\pm 0.5^{\circ}\text{C}$
		PT100	$-100 < TS \leq 100^{\circ}\text{C}$	± 0.2 (must be customized)	
A/D converter		Mode: $\Delta \Sigma$, 16Bit(Effective resolution: $\pm 1/40000$)			
Maximum input voltage	Between input terminal +/-	-100V~100V: p-p			
	Between channel (1-1/(-1))	60Vp-p			

	Between input terminal/GND	60Vp-p
Maximum withstand voltage	Between channels	350Vp-p(within 1 minute)
	Between input terminal/GND	350Vp-p(within 1 minute)

1.Does not include the reference junction compensation accuracy.

2.Rated current: 1mA

3.Situation of connecting under 4 units:

The specification of the above is 23℃+5℃, which is adjusted at zero point after preheating.

3.3 Alarm output

Relay output: contact rating AC 220V, 3A, resistive load;

16 point parameter setting output,can be set according to the alarm point of each channel.

3.4 External power supply

DC 24V: supply power for transmitter ,maximum load capacity ≤200mA

3.5 Communication print interface (optional)

Photoelectric isolation

The standard RS232&RS485 communication,

Communication rate 9600、19200、57600、115200 are chose by settings.

Matching testing software including parameter setting software and application software can provide support. Optional Modbus RTU communication protocol and PC communication.

3.6 Power conditions

AC 220V power meter: AC 85~265V, power consumption is less than 20VA;

DC 24V power meter: 24V + 10%, power consumption is less than 20VA.

Note: the actual power consumption is related to the total number of channels

3.7 Environment and others

Working temperature range: -10°C~50

Storage temperature range: -20°C~70°C

Working humidity: less than 85%R.H, no condensation

Weight of instrument (64 channels): the maximum weight is about 3.8Kg

3.8 Recording time

The length of time is related with available capacity of FLASH memory (available capacity=total capacity - used capacity (internal procedures are generally 10M)), Recording interval is related with the input points, For the convenience of users to expand channels, we set the record channel points as 64 channels, the calculation formula is as follows:

$$\text{Record days} = \frac{\text{Available memory } 70 \times 1024 \times 492 \times \text{Recording interval}}{\text{Channel number } \times 24 \times 3600}$$

FOUR: Installation & wiring and structure

4.1 Outline and mounting hole size

- ❗ To ensure safety, the wiring must be carried out after power off.
- ❗ AC power supply instrument, its \perp (PG) end is the common end of the power filter, with high voltage and can only be connected to the grounding terminal. It is prohibited to connected with other terminals.

This specification provides basic wiring diagram limited by the number of terminals. When the instrument function and the basic wiring diagram conflicts with each other, the wiring diagram shall be subject to instructions in the instrument.

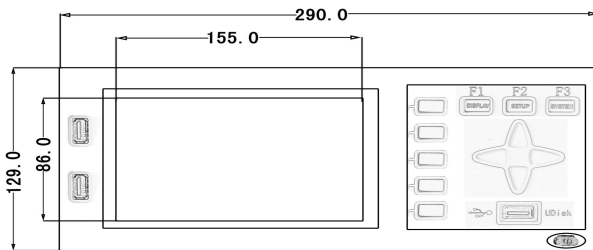

Dimension: 129×290×300mm(Height * width * depth)

4.2 Terminal diagram

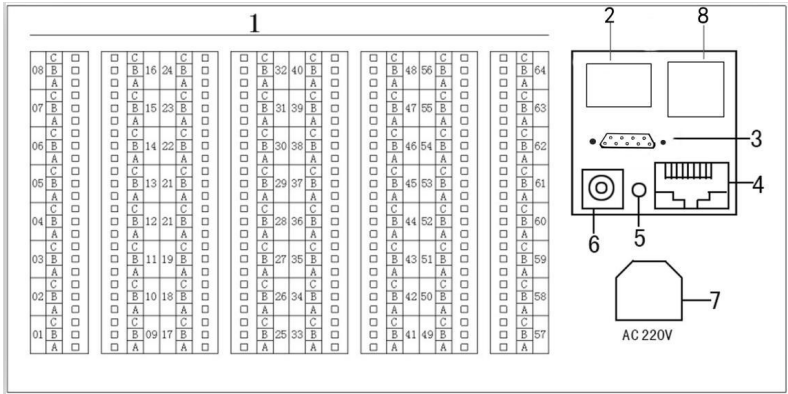

1. Signal input (measurement module installation slot)

Module installation order from the lower left corner of the M1 (1 ~ 8 channels) to the right M2 (9 ~ 16 channels) to the top layer of the left M3 to the right M4 by order. On the top left is M7 and right M8 (57 ~ 64 channels). Relay signal's output module is generally insert into M8.

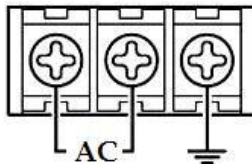

2. DC DC24V output terminal

DC 24V ($\pm 5V$) Power supply output interface for external sensor

3. RS232 communication interface

DB9 wiring: the second pin is "RXD" (RS232) of the instrument, the third pin is "TXD" (RS232) of the instrument, the fifth pin is communication "grounding".

4 Two usages of net mouth

1) Download the project

Download configuration through the MCGS embedded software then choose to run online, select TCP/IP communication, modify the target instrument's IP address (the target instrument refers to the screen, the default IP address 200.200.200.190), then click on the download project,

2) Communicate with the lower computer

Communicate through the TCP/IP protocol and the lower machine, such as with the SIEMENS Smart200, 1200, 1500, MITSUBISHI FX3U, FX5U series PLC; and support ModbusTCP/IP protocol of all kinds of lower computer instrument's communication.

(that is, as long as both the lower computer and the host computer using

ModbusTCP/IP protocol, they can communicate with the instrument

5. Ambient temperature sensor (18B20)

6. DC24V input terminal

7. AC85-265V power supply input terminal

8. Wifi signal antenna

4.3.1 Wiring way of input signal

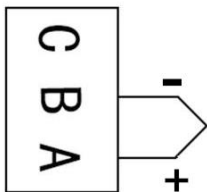
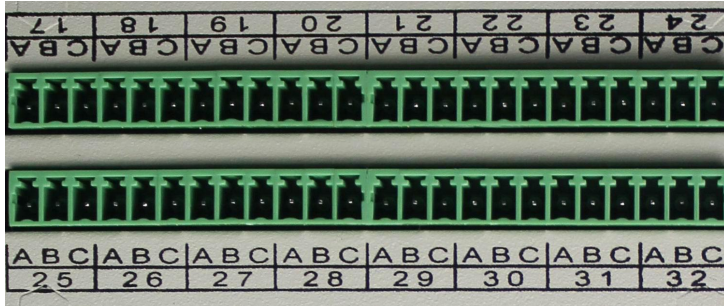

Thermocouple
signal access

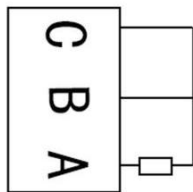

Thermal resistance
signal access

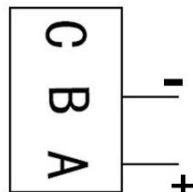

Voltage
signal access

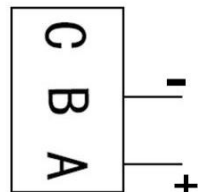

Current
signal access

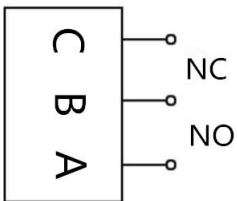

Resistance signal input

25-32 represent eight channels, A,B,C represents three terminals of each channel; thermocouple signal input:input of A foot signal is positive, input of B foot signal is negative; Current signal input:input of A foot signal is positive, input of B foot signal is negative; voltage signal input:input of A foot signal is negative, input of B foot signal is positive; Resistance signal input:resistance connects with A,Bfoot, BandC shortly connected; Switch signal input: input of B foot signal is positive,input of C foot signal is negative.

4.3.3 Wiring and installation instructions of relay output signal

Relay output module JK1718 is inserted into the back of the instrument where is the upper right corner of the M-8 notch, when the alarm set in a channel of the upper or lower limit, set the upper and lower corresponding to contact number in the parameter setting window (Contact No. 1 corresponding to relay module channel No. 1 port, Contact No. 8 corresponding to relay module channel No. 8 port, switch signal output port + -, relay is normally open type); Example: upper limit of first channel is 50, you can set any of the corresponding contact 1 ~ 8 in any one relay contact, second channels of the upper or lower limit value can be set from 1 to 8 in any one contact, a contact by the end of the set, when the channel value exceeds the set upper or lower limit, or the corresponding lower limit relay will work normally; but also can set the hysteresis value, hysteresis refers to When the relay work, the channel value of the difference in value back to limit the relay to stop work (such as the upper limit is 50, a channel value has exceeded 50, hysteresis value is set to 2, then this channel will contact the corresponding relay on this channel,

when the display value is less than 48 at the corresponding channel contact the relay can be off to stop work).

Five. Instrument operation and parameter setting

The touch type data recorder with a number of operation display screen and parameter setting interface which has clear display, large amount of information and convenient parameter setting. The user can easily operate the instrument without professional training.

7 inch screen:

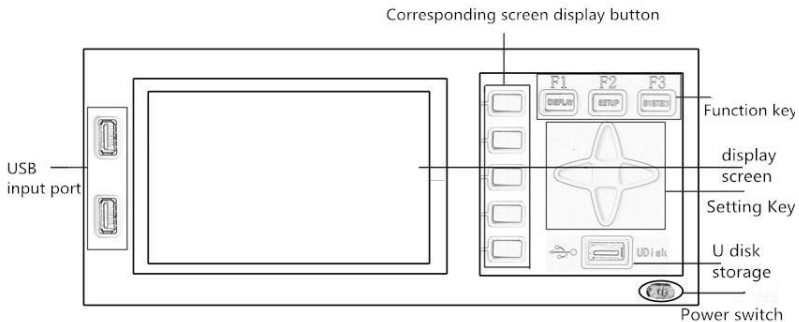

After the instrument connected with the power supply, the system interface is displayed. Boot system is completed, enter the real-time numerical display interface. The following are the introduction of the keyboard operation of the instrument, display screen of each operation, screen of the parameters setting. Click the settings button, you can choose to enter the parameters set screen. (New machine has not set up the password), press “enter confirmation” key can start the parameters set.

System parameter setting

System parameter settings are mainly used to set the system date, system time, storage interval, IP address and other parameters, SMS alarm telephone number settings will be introduced in the following 5.10

Instrument parameter setting

Channel parameter setting screen is used to set signal types, station number, engineering units, range limits, filtering, constant flow parameters (small signal excision, square), grand total and alarm settings of each channel.

After the instrument connected with the power supply, the system interface is displayed. Boot system is completed, enter the real-time numerical display interface. The following are the introduction of the keyboard operation of the instrument, display screen of each operation, screen of the parameters setting. Click the settings button, you can choose to enter the parameters set screen. (New machine has not set up the password), press “enter confirmation” key can start the parameters set.

System parameter setting

System parameter settings are mainly used to set the system date, system time, storage interval, IP address and other parameters, SMS alarm telephone number settings will be introduced in the following 5.10

Channel parameter setting screen is used to set signal types, station number, engineering units, range limits, filtering, constant flow parameters (small signal excision, square), grand total and alarm of each channel.

The modify of channel numbers and measurement unit can click settings and then enter the parameter settings.

%	K	Ω	‰	°F	°C	m/s	g
Kg	mm	cm	m ²	m ³ /h	r/min	W	mA
A	mV	V	Pa	KPa	MPa	Hz	Confirm

Signal type

The instrument supports a variety of signal types, including analog signals to support universal input, change the different signal types, as long as the change in the terminal wiring and set up the corresponding signal type. When setting the signal type, please note that it should be consistent with the signal of a meter or a detecting element.

Open square and small signal removal

Open square and small signal resection with the use of small signal removal range can be set to 0~25.0%. The effect is that when the measured value is small, the measurement error is large, especially in the following 1%, the accuracy will be greatly reduced.

Transmit output

The parameters on the transmission output has three output channels, analog output limit, transmission output limit, the type of the output signal has been set at the factory, these parameters are put in the picture set channel parameters, output channel number is in the range of 1~8, use an additional note.

The channel function of the channel (virtual operation channel) channel can be divided into physical channel and virtual operation channel, But can increase the operation of the channel, such as the physical channel between the measured value of a simple operation to achieve, the operation of the way to add, subtract, multiply, divide. The channel involved in the operation is only physical.

5.1 Running screen

In the running process of the data recorder, the picture is displayed as the running screen, including the numerical display interface, the bar graph, the curve interface, the alarm interface, and the settings button, parameter settings, system settings, etc.. Which shows the interface, bar chart, real-time (History) curve for the common screen picture. 8 channel screen adds a comprehensive interface. The upper right corner of the screen displays the current date and time.

5.2 Boot screen

The screen will display the click screen to start the property window, then we do not need to click on the screen, so that the screen directly into the boot screen display.

5.3 Display interface

The display interface can have a more comprehensive understanding of the current situation, including the channel name, the measured value, the amount of units, alarm instructions, alarm output status

5.4 Digital display interface

The digital display screen is divided into 64, 48, 40, 32, 24, 16, 8 channel digital display screen (8 channels have a comprehensive display picture) users can enter parameters setting to choose channel number by pressing setting button which will show required channels on display interface.

The following is a 8 channel display interface.

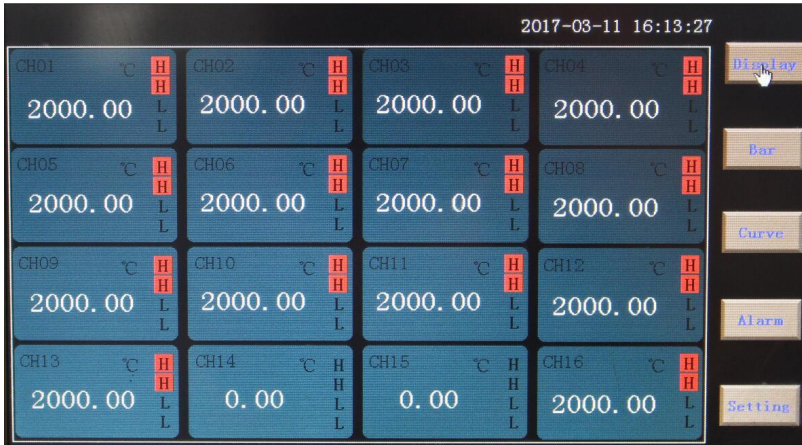

The following figure shows the specific content of a single channel, which contains the channel name, unit, measured value and alarm signs in four parts. Alarm signs has four levels upper limit alarm/ up limit alarm /lower limit alarm / low limit alarm. When the value is normal, the alarm sign turns green. When the value exceeds, the corresponding alarm sign will change to red . Alarm value can be set in the parameters setting.

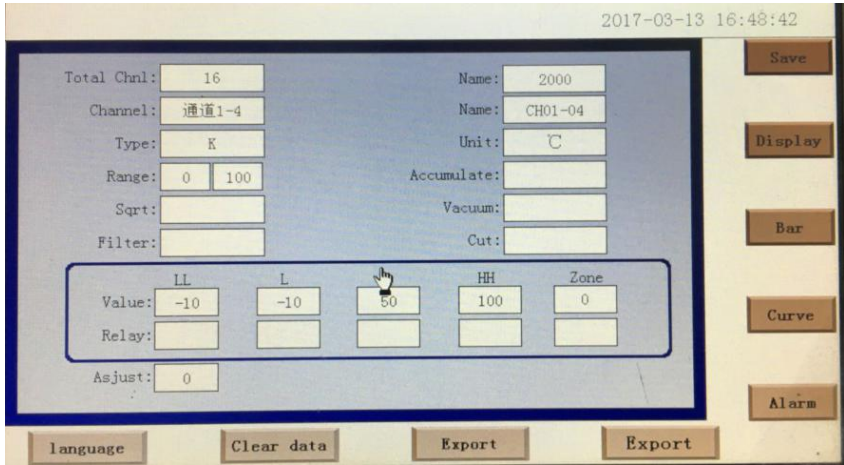

Click on the box then it will pop up a small window which shows basic information of the channel, small window shown as above.

Button introduction: there are six buttons at the bottom of the interface (save, display, bar graph, curve interface, alarm interface, set).

Save: when setting the parameter, the current set of parameters become initial parameters and are written to disk, to prevent losing parameters if power off. (now the product has been updated with the instrument system, it automatically storage parameters, without the use of the Save button)

Curve interface: switch button, press this button can switch to the curve interface, which is divided into real-time and historical display.

The alarm interface: switch button, press this button to switch to the alarm interface, on the bottom there is an alarm button, press this button to view the historical alarm data. You can choose time period to view the history of alarm data. (below)

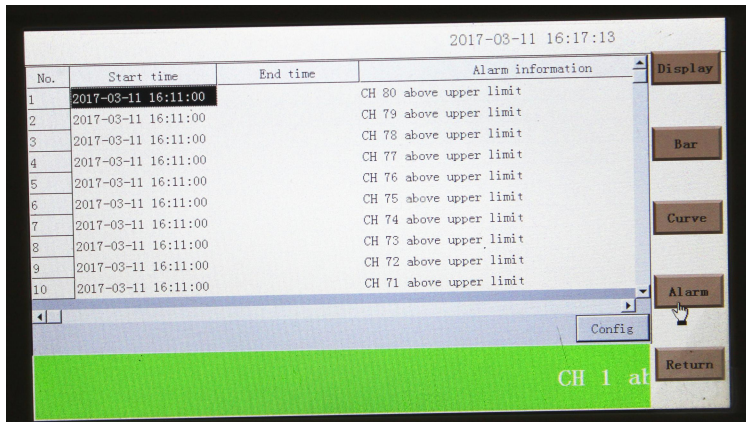

Settings: there is settings button under display interface, which can enter the parameter settings and system settings. Click "Set" then select parameters".

(New instruments have no password: click yes to set directly!)

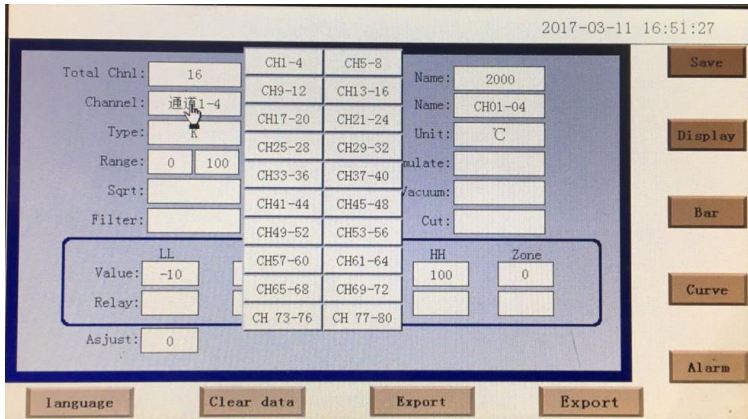

In the parameter settings interface which can set all the parameters such as the number of channels, the channel name, the type of channel number , range, units and other parameters set. If you need buttons like vacuum\accumulate\extract a root\filtering\cutting used for gas flow or water flow, you need to customize it.We attach instruction in the flow test products.

System setting interface

In this interface you can press "Settings" button to enter the password/alarm switch/storage interval/system time/screen switch/ time of screensavers/ network port communication IP address and other information. The phone number is customized for GPRS SMS alarm. On the right is number about system version for the reference of the customer service maintenance system. There is also a brief instruction of usage.

5.5 Integrated interface

Integrated interface is only for '8 channel display interface', as shown below. In the integrated interface, the digital display interface/ the real-time curve interface/the bar graph interface and the average value bar chart display interface are combined together. Give customers a new look at the overall situation.



5.6 Bar chart display screen

Bar chart interface: press switch button to switch to the bar chart interface. There are four images, respectively "1-16 bar chart" 、 "17-32 bar chart" 、 "33-48 bar chart" 、 "49-64 bar chart" , using cyclic flip mode to switch pages. The following is 1-16 channel bar charts images.



The above figure shows the specific contents of the bar graph interface channel, which includes the channel name, the value and the percentage bar chart display. The bar chart channel also has the alarm function, when the channel value is greater than the upper limit alarm value or lower than the lower limit alarm value, the percentage fill color will become red, the display unit as a percentage.

Bar graph interface button function and display interface is similar.

5.7 Real-time curve images

The current curve record only keeps the display data of single screen, and it can change the Y axis and the time scale X axis to change refresh speed, each curve is consistent, does not affect the time interval of FLASH records. (picture shown below)



In the real time curve shows the current channel measurement, channel number, station number, the amount of units, the curve of the RBI interval, alarm status.

The range of the set: the real-time curve above the screen can be set X, Y axis range label, the curve will be based on the range you set to make the appropriate changes.

Real time curve display function: button the button on the bottom of the picture and similar to the bar graph interface, the upper right corner of the button to toggle button, it can real-time curve view more channels and duration curve.

5.8 history curve

The FLASH record is used for long term data storage, and the record

interval is longer; the recording interval is selected from 1 second to 9999 seconds. According to the needs of the production process, the FLASH record interval is set reasonably, and the contradiction between the recording interval and the time can be accurately reflected. Set the record interval time in the display interface to set the button to enter the system parameter test set time interval, in the following introduction) (below)

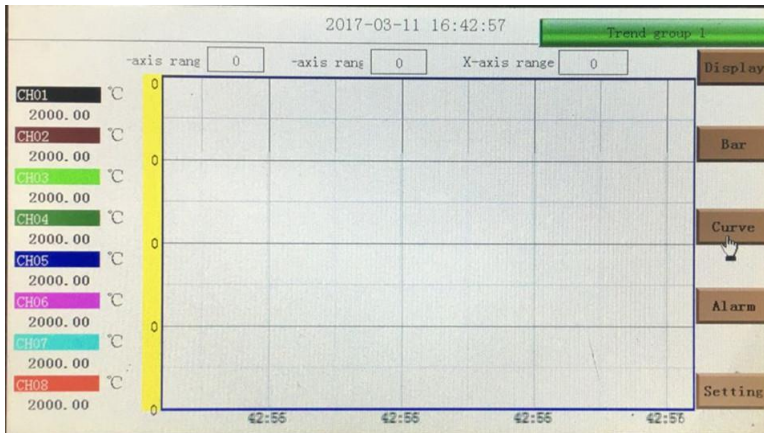

The timescale in recall mode cannot be changed by the record interval determined by FLASH. The time in the recall mode is shown as the time of the right side of the curve. The alarm status indicator in the recall mode is still a real-time alarm state, not a record state. The reading cursor mode is used to accurately display the values of each point of the recall curve. The value at the top of the cursor is the actual value of the current channel at the cursor, and the time at the top right of the screen becomes the cursor position. Unable to forward or backward in cursor mode.

The button shown below, from left to right in the function is: to the X page, scroll left axis curve to the left half of the rolling curve X axis to X axis, is a main line rolling position, scroll to the right end of a main shaft of X line position, X axis to the right end of the rolling curve half a page to the X axis, the right end of the rolling curve and page settings.



Other button functions refer to real-time curve display.

Note: 1 If the recorder has been power down, there will be no data records during this time. Though the curve will be interrupted, historical data will not be lost.

2 If the recorder changes the recording interval during the operation, there might be interval or inaccuracy of the historical data .

5.9 parameter setting interface

Channel parameter setting screen is used to set the signal type, set each channel station number, engineering units, range limits, filtering, constant flow parameters (small signal excision, square), cumulative, alarm limit, limit alarm, alarm alarm limit, lower limit, relay output contact number selection set.

Channel number: refers to the number of channel display interface display, such as 8, 16, 24, 32, 40, 48, 64, 16, 8 respectively, representing 24, 32, 40, 48, 64 channels in one interface, according to the different needs of different channel number set.

Channel: channel selection, select a channel, and then set the name, type, unit, range, lower limit, lower limit, upper limit, upper limit, the adjustment is to set the channel properties.

Contact: used to set the lower limit or the upper limit of the alarm output point, used to trigger the relay module action channel number, in the 4.3.3 specification has been introduced.

channel name Type of channel

channel unit

Range: the range of the channel, the setting range is very important for bar graph display. Upper limit, upper limit, lower limit, lower limit: four alarm value of the channel. Adjust: adjust the value of the channel to make it display the ideal value. By adjusting the K value to adjust the temperature (MD), multiple adjustment b value can adjust the value of the value of the size of positive and negative.

Button function

Remove the accumulated: remove all data disk. Replication: you can copy the parameters of a channel. Paste: paste the copied channel parameters to the current channel. Data export: switch button, press this button to enter the data export interface (the import data

U disk insert instrument USB port).

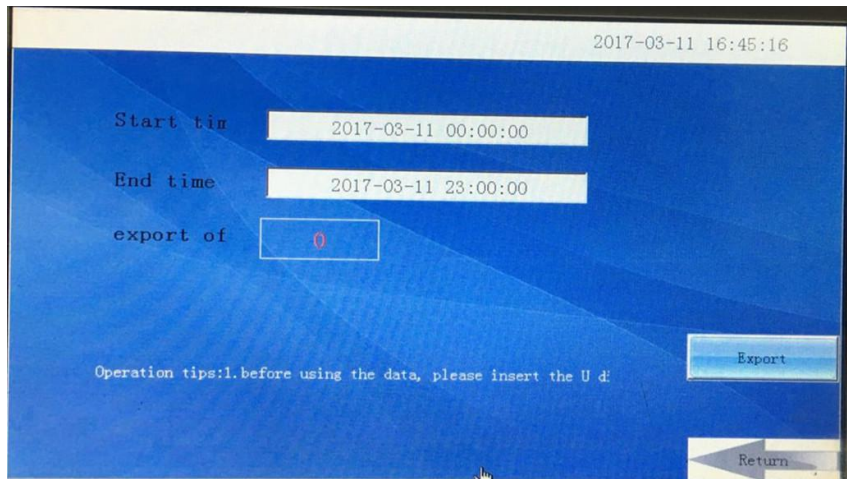

In the data export button which contains the "quick export data" and "export

data" button two. The difference between the export of historical data and the export of historical data:

One. Quick export data

Advantages: fast, when the instrument data reached tens of thousands, probably by 30s time data can be derived, in the rapid export data does not support time, namely the instrument in all history data. Disadvantages: 1, in the period of time will stop exporting data within the instrument data collection and storage, which quickly export historical data process, other processes are in a dormant state, when export data is completed, they will be awakened; 2, derived from the data stored in the U disk data folder, generated data the document requires the use of special software the company computer can open access.

Two. Data export advantages:

1, in the export data, instrument can still perform data acquisition and storage and other functions, the other in the implementation process is still does not need sleep, and can set the selection time of export data. 2, the data is stored in the root directory of U and in the way of time named by Excel (open access table to use PC software to check, cannot change the file, otherwise the PC software can not identify the file) disadvantages: export data is slow, which is derived using a long time, if tens of thousands of data, export data may take more than and 10 minutes or more. The above is the difference between the two, the user needs to operate according to their own needs Language: select the language switch button, you can switch between Chinese and English display.

5.10 System parameter setting interface

The system parameters include: date, recording interval, password setting, network communication IP, buzzer alarm, temperature rise, screensavers, equipment.

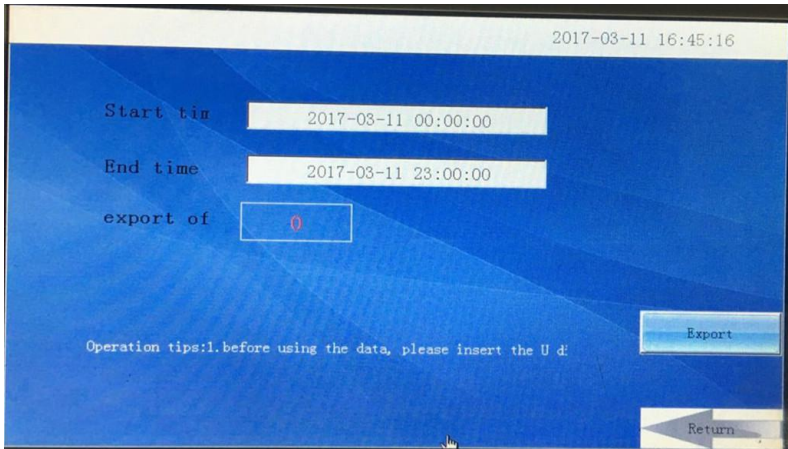

Date: set the date and time of the current system. Recording interval: data storage interval, have a direct impact on the data set the logging interval density derived. Password settings: Click to enter the user manager, you can modify the user password, add new users, delete Household operation.

Buzzer alarm: click the toggle switch buzzer alarm function. The screen saver settings: set the screen saver to open and close the open state can set the screensaver time, after a set time

Instrument display will not light, into the power saving state. Temperature

rise: This is used for electric power switch contactor parts when measuring temperature rise, when the temperature rise, you can choose

The optional ON, normal temperature we are OFF state, ON state when choosing the instrument will at the end of a channel subtracting the first channel temperature from second channels, the other channel temperature value than the first channel temperature value of a temperature rise value, then the first channel temperature probe should be placed in the air.

Ethernet communication function:

The 10 inch screen recorder network communication IP settings: check the router specification, different types of router's IP address is not the same, some are 192.168.1.1, some are 192.168.0.1; to: 192.168.1.1 for example: IP address set: 192.168.1.*, * from between 2 to 254, can be set for LAN IP address. The IP settings in the software should be consistent with the instrument, the target port is set to 3000.

SMS alarm settings:

This function is designed for customized SMS alarm function of the instrument, with the GPRS SMS sending module to send text messages, as long as the need to enter the phone number to receive sms.

5.11 alarm interface

The alarm interface includes two parts: browse table and scroll bar. Browse the table can query the alarm data at any time, the scroll bar only displays the current alarm information. Browse through the lower right corner of the table "Settings" button can enter the "set time range" of the small window, the time to set up to query the alarm information.

2017-03-11 16:17:13

No.	Start time	End time	Alarm information
1	2017-03-11 16:11:00		CH 80 above upper limit
2	2017-03-11 16:11:00		CH 79 above upper limit
3	2017-03-11 16:11:00		CH 78 above upper limit
4	2017-03-11 16:11:00		CH 77 above upper limit
5	2017-03-11 16:11:00		CH 76 above upper limit
6	2017-03-11 16:11:00		CH 75 above upper limit
7	2017-03-11 16:11:00		CH 74 above upper limit
8	2017-03-11 16:11:00		CH 73 above upper limit
9	2017-03-11 16:11:00		CH 72 above upper limit
10	2017-03-11 16:11:00		CH 71 above upper limit

Display

Bar

Curve

Alarm

Config

Return

CH 1 at

SIX. Communication settings and communication protocol

Communication is through the communication interface, the computer can read the measured value of each channel, alarm status. Read all parameters of the instrument, and set parameters.

This series of data recorder provides two kinds of communication with the host computer, the RS-232, RS-485 standard interface for the user, RS-232 is suitable for point-to-point short distance communication, which is mainly used for communication instrument and portable computer; RS-485 communication is applied to a multipoint long distance, mainly in multiple instruments networking and use when communicating with a computer. The specific choice of what kind of communication by the user depending on the needs and specific circumstances. This instrument uses ASC II and MODBUS communication protocol. And provide a variety of industrial software, such as parameter setting software.

6.1. Overview

Clean the RS-232 only allows a computer to hang a recorder. This communication mode is suitable for the use of portable computer users random read data recorder; also can connect the radio remote wireless transmission or connect the serial printer to print the data and curve recorder.

Large RS-485 allows a PC while hanging multiple recorder. This communication mode is suitable for using terminal users and the series instruments constitute a network, real-time receiving and data recorder and various control system.

6.2. RS-232 communication mode

Clean the RS-232C communication interface, end users only need to be equipped with RS-232 three core communication lines connected to the instrument RS-232C interface, and the other end of the portable machine (or PDA) serial port is connected, we can realize RS-232 communication connection.

In the large recorder system parameter setting, selection of address and baud rate, and the corresponding set in the computer management software, can carry out RS-232 communication.

The connection with the computer is shown in the following figure:
Figure RS-232 communication wiring method (instrument internal 2, 3 feet cross connection)

Definition of communication interface connection

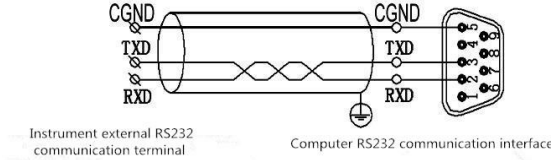

6.3 RS-485 communication mode

This large series of RS-485 communication line data recorder using shielded twisted pair, one end of the conversion of serial communication module connected to the computer through the RS-232/485 port, the other end is connected to a communication terminal recorder.

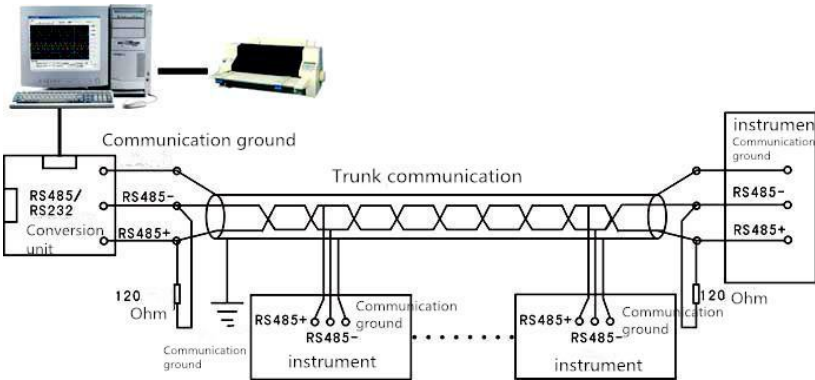

The connection is shown in figure:

In the large recorder system parameter setting, selection of address and baud rate (fixed to 9600).

Large shield dual core shielded cable as communication wire, attention can not be connected with equipment protection. When the transmission distance is far away, both ends of the transmission line are respectively provided with a 120 terminal resistor, which is connected between the RS-485 communication line "+" and "-".

Luggage when a computer is hanging a plurality of recorder, the network topology is always linear, every recorder is connected in line by line. It should be noted that the terminal resistance to be connected at both ends of the

communication trunk, the branch of the transmission line as short as possible to reduce interference.

Large long distance communications can choose relay module.

6.4 Communication test

In the connected computer and recorder connection, check the baud rate of host and recorder device address and are consistent with the "serial debugging assistant" on recorder orders, see if there is an answer recorder.

6.5 Communication interface

RS-232/RS-485, Ethernet interface.

6.6 Modbus RTU

The communication between computer and temperature recorder is based on Modbus protocol.

ModbusRTU Communication command:

	Function code	Function	Send frame	Receive frame
1	0x03	Read one or more register data	Device address: 0xXX Function code: 0x03 Start address High: 0xXX Start address Low: 0xXX Register number High: 0xXX Register number Low: 0xXX CRC check Low: 0xXX CRC check High: 0xXX For example send: 01 03 00 00 00 08 44 0C	Device address: 0xXX Function code: 0x03 Data length n: 0xXX date 0: 0XXXXX date n-1: 0XXXXX CRC check Low: 0xXX CRC check High: 0xXX reply: 01 03 10 00 00 00 00 00 00 00 00 00 00 00 00 00 00 E4 59
2	0x06	Write Single register data		
3	0x10	Write multiple register data		

4	0x11	Read device informatio n		
---	------	-----------------------------------	--	--

6.7

Generation of 6.6CRC

The cyclic redundancy check (CRC) field is two bytes and contains a binary value of 16 bits. The value of the CRC appended to the message is calculated by the sending device. The receiving device calculates the value of the CRC at the time of receiving the message, and compares the calculated result to the actual received CRC value. If the two values are not equal, then the error.

The process of generating CRC:

- (1) a single bit register is loaded into a binary FFFF (all 1). It is referred to as the CRC register () in the register.
- (2). The message of the first 8 byte and 16 bit CRC register low byte XOR, results in the CRC register.

- (3). CRC (1 LSB to register the right direction), MSB extraction and detection of LSB zeros.
- (4). (if LSB is 0): repeat step 3 (another shift). (if LSB = 1): the CRC register value 0xA001 (1010000000000001) XOR polynomial.
- (5). Repeat steps 3 and 4 until the completion of the 8 shift. When this is done, the complete operation of the 8 bit byte will be completed.
- (6) Repeat step 1 to 5 in the next byte of the message and continue until all messages are processed.
- (7) The final content of the CRC register is CRC.
- (8) When the CRC value is placed in the message, the high and low bytes must be exchanged.

6.8. Modbus TCP

ModbusTCP Communication command::

	Function code	function	Send frame	Receive frame
1	0x03	read one or more Register data	Transaction identifier High:0xXX Transaction identifier Agreement High:0x00 Agreement Low:0x00 Length High:0x00 Length Low:0x06 (the length is the number of bytes in the orange part below) Device address: 0xXX Function code: 0x03 Start address High: 0xXX Start address Low: 0xXX Register number High: Register number Low: CRC check Low: 0xXX CRC check High: 0xXX For example send: 00 01 00 00 00 06 01 03 00 00 00 08 42 E9	Transaction identifier High:0xXX Transaction identifier Agreement High:0x00 Agreement Low:0x00 lengthHigh:0xXX lengthLow:0xXX (the length is the number of bytes in the orange part below) Device address: 0xXX Function code: 0x03 Date length n: 0xXX datet l: 0xXXXX Date n: 0xXXXX reply: 00 01 00 00 00 13 01 03 10 00 00 00 00 00 00 00 00 00 00 00 00 00 00 00 00 6D AB

2	0x06	Write single register data		
3	0x10	Write multiple registers the data		
4	0x11	Read device information		

Seven. Communication software instructions

7.1 System login

1. Find  JINKO V16.1 in -1020-2, double click then operate the system.



7-1 JINKO V16.1 Application Icon

2. Double click, then it will pop up main system of interface. Shown as 7-2.

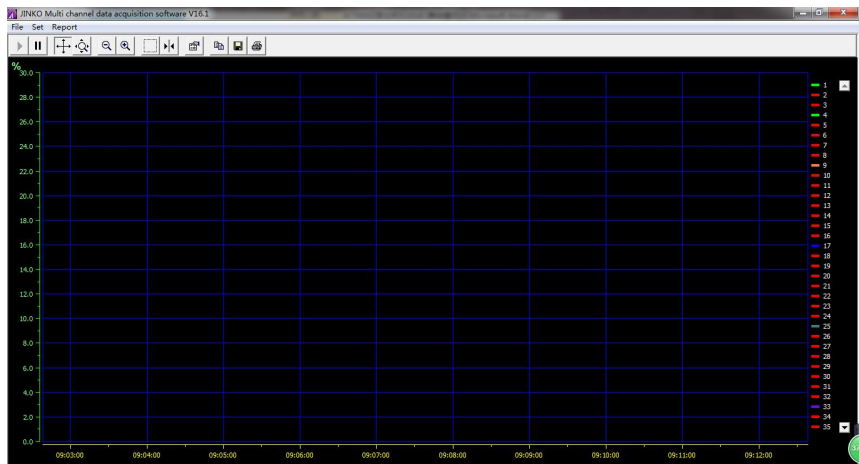

Figure 7-2 JINKO V16.1 main window

7.2 System interface introduction

1. Display area of system name: show in top left corner
2. Main menu: Contains 3 options "File(F)", "Settings", and "about"
 - 2.1 "File(F)" contains "open (CSV)", "Real time acquisition", "Close acquisition", "Close".

2.2 Setting options contains “serial port settings”, “curve settings”, “data comparison settings”, and “parameters settings”

2.3 “About” option, provide version information of the system for users

Toolbar : Includes 12 options: tracking display, zoom in and zoom out, cursor, window preview, attributes, save and print

2.4 Main window of display: The collected data are displayed in different ways, such as historical data and alarm record query etc. display area.

7.3 Set up equipment and communication settings

7.3.1

Set up equipment

In the "Settings" column, select the device parameters as shown in Figure 7-3 new device pop-up dialog box, the device name from the name, the device address for a device name, according to the need to select the corresponding channel number and the initial channel (default channel 1). Operation: 1) to build a new 16 channel equipment, equipment type (choice of communication protocol, which **w said wireless protocol) - > device name - > device address is 1 (default instrument address = 1) - > Channel 8 channel number

- start channel 1; 2)

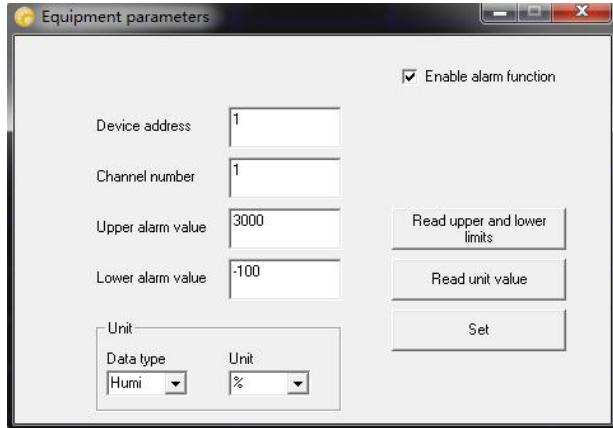

Picture 7-3 new device dialog box

The system also provides more than 1 pairs of communication, that is, the system can simultaneously monitor multiple instruments. If you have more than one instrument to monitor at the same time, you can carry out the following operations: 1) in the instrument set up the system interface will be set to the address of the device 1, 2, 3..... In the system, the corresponding channels are respectively set up in the device, wherein the device address is set to be the same as the device address of the instrument. If there are two instruments, the first device address is set to 1, second sets of equipment to address 2; to build a device in the system: device name -> device address is 1 -> start channel 1; then set up another device: the device name -> Device address 2 - - start channel 1.

1) Serial communication

The instrument support serial communication which is connected through the RS232 of the computer and RS232 port of the

instrument. You can click the drop-down box to choose. The baud rate is 9600 by default settings. Click on the serial port settings and open the serial port. As shown in Figure 7-4

如图7-4



7
-
4

serial port settings

7.3.2 data display mode

The system provides a variety of data display: curve, digital display, and integrated display. Double click the 1 column of the equipment, then set the curve can be selected, set the parameters, in the main menu bar "real-time" option in the toolbar or select a data display, here only to explain the choice of curve shows (Figure 7-5 default curve interface). As shown in Figure 7-6 in the main menu bar select "file" in the "real time collection" button to display the sampling settings window, start with the lower machine to establish communication, and select the save path and file name. After the start of the sample, the software will automatically read the data according to the sampling frequency and automatically save as Excel file format.

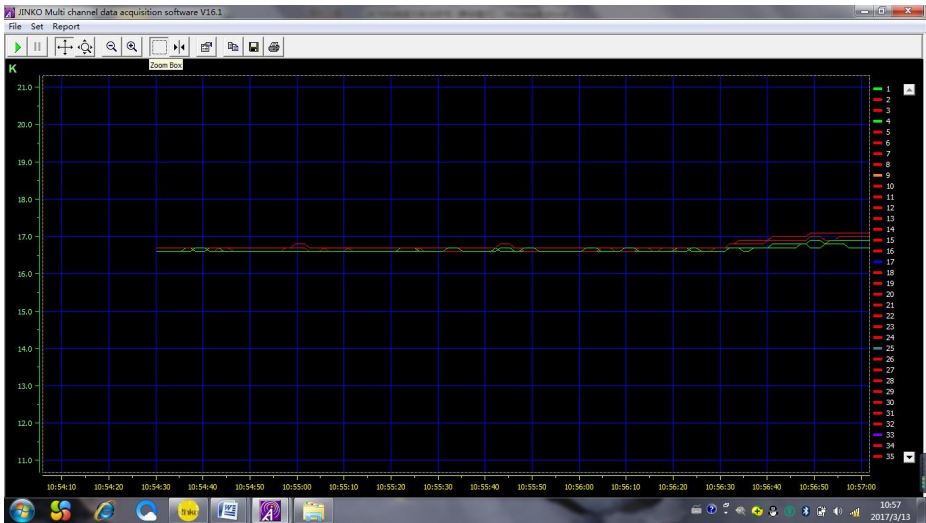

7-5 Curve interface

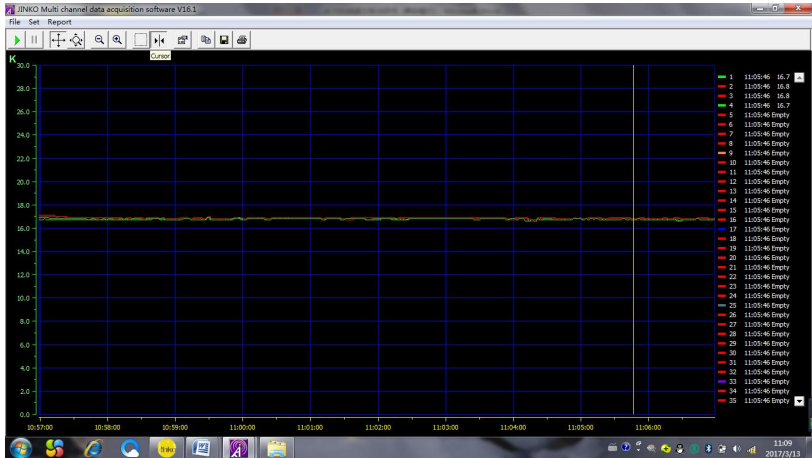

Data direct display

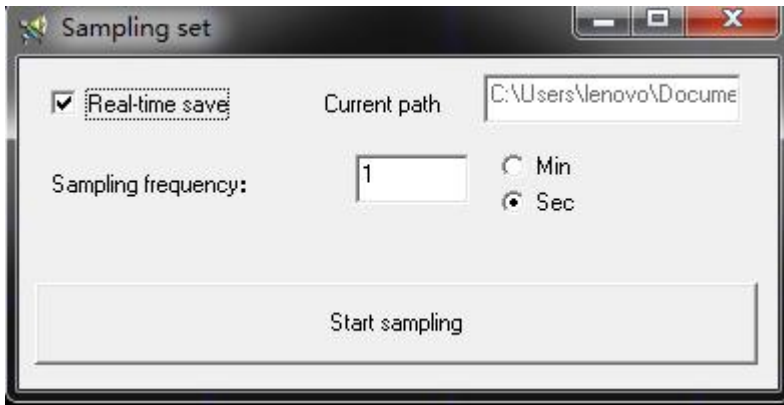

7-6 Save path

Total Preview							
Label1							
wd1-1:	K	通道33:	%	通道65:	%	通道97:	%
y1-2:	Ω	通道34:	%	通道66:	%	通道98:	%
通道3:	% _o	通道35:	%	通道67:	%	通道99:	%
cc2-4:	%	通道36:	%	通道68:	%	通道100:	%
通道5:	%	通道37:	%	通道69:	%	通道101:	%
通道6:	%	通道38:	%	通道70:	%	通道102:	%
通道7:	%	通道39:	%	通道71:	%	通道103:	%
通道8:	%	通道40:	%	通道72:	%	通道104:	%
通道9:	%	通道41:	%	通道73:	%	通道105:	%
通道10:	%	通道42:	%	通道74:	%	通道106:	%
通道11:	%	通道43:	%	通道75:	%	通道107:	%
通道12:	%	通道44:	%	通道76:	%	通道108:	%
通道13:	%	通道45:	%	通道77:	%	通道109:	%
通道14:	%	通道46:	%	通道78:	%	通道110:	%
通道15:	%	通道47:	%	通道79:	%	通道111:	%
通道16:	%	通道48:	%	通道80:	%	通道112:	%
通道17:	%	通道49:	%	通道81:	%	通道113:	%
通道18:	%	通道50:	%	通道82:	%	通道114:	%
通道19:	%	通道51:	%	通道83:	%	通道115:	%
通道20:	%	通道52:	%	通道84:	%	通道116:	%
通道21:	%	通道53:	%	通道85:	%	通道117:	%
通道22:	%	通道54:	%	通道86:	%	通道118:	%
通道23:	%	通道55:	%	通道87:	%	通道119:	%
通道24:	%	通道56:	%	通道88:	%	通道120:	%
通道25:	%	通道57:	%	通道89:	%	通道121:	%
通道26:	%	通道58:	%	通道90:	%	通道122:	%
通道27:	%	通道59:	%	通道91:	%	通道123:	%
通道28:	%	通道60:	%	通道92:	%	通道124:	%
通道29:	%	通道61:	%	通道93:	%	通道125:	%
通道30:	%	通道62:	%	通道94:	%	通道126:	%
通道31:	%	通道63:	%	通道95:	%	通道127:	%
通道32:	%	通道64:	%	通道96:	%	通道128:	%

7-7 Digital display interface

remove total preview:

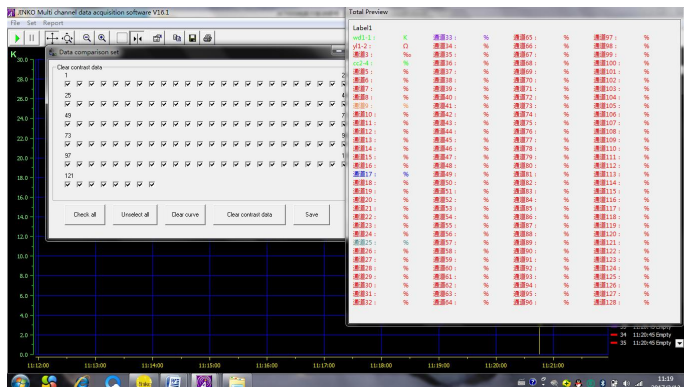

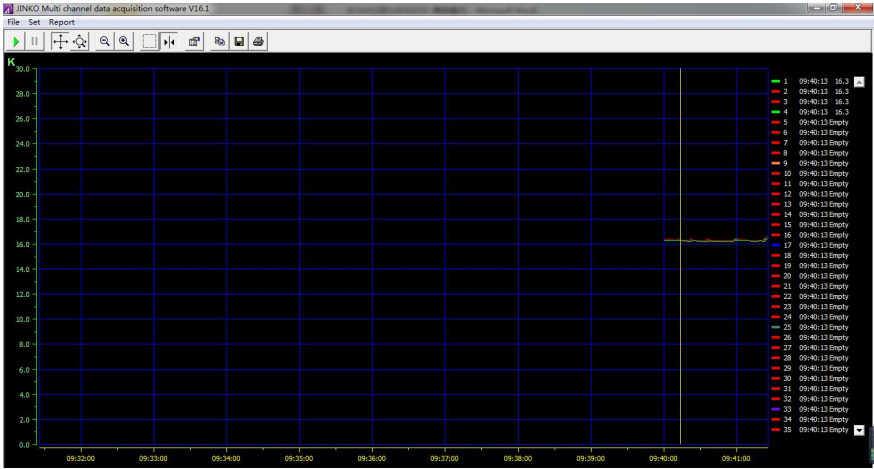

7-8 Integrated display interface

The parameters of each channel can be set in the column, select the appropriate channel click the left mouse button to set the device properties. The following figure 7-9 channel attribute set, this window can be arranged inside the device name: the name of the channel, channel number, channel unit, display color, background color, the X axis shows the time limit and offline operation of Y axis. Before collecting data, click on the initialization unit to keep the Y axis unit in line with the first channel.

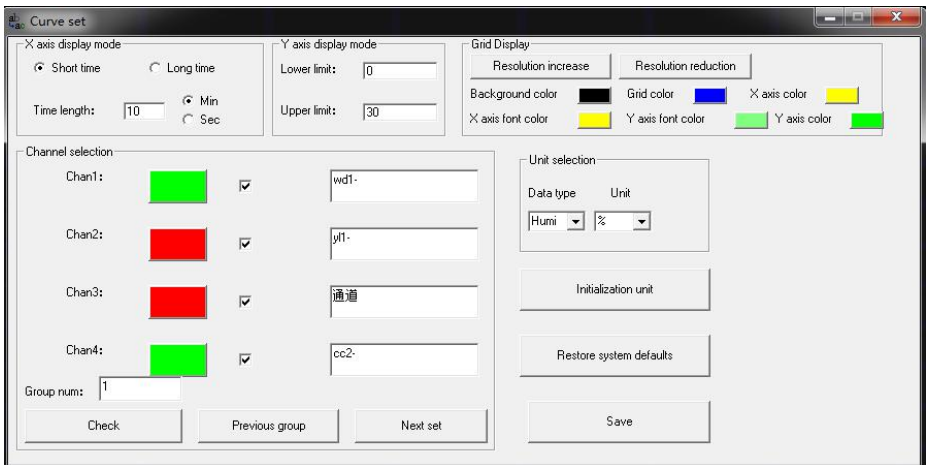

7-9 Settings of curve property

7.3.3 Alarm setting

The system provides users with intelligent alarm message service, this service needs to connect external SMS alarm equipment (computer terminal external wireless SMS alarm devices such as T3-DTU, shown in Figure 7-10, alarm equipment described below refer to T3-DTU device), is through changing the device to send SMS SMS message to notify the administrator according to the content of the message management, not sure whether or not to the scene. Specific settings: select the main menu bar in the "Settings" option, select "device parameters" to open the alarm function, as shown in figure 7-11.

The alarm is arranged below the interface can read or write equipment each channel of the upper and lower limit, mainly for alarm service, the lower limit is greater than the channel of data channel is less than the upper limit or channel, the instrument will display the alarm information. Read the upper and lower limits to see the upper and lower limits of the channel. The unit symbol can be consistent by reading unit values and the lower machine.

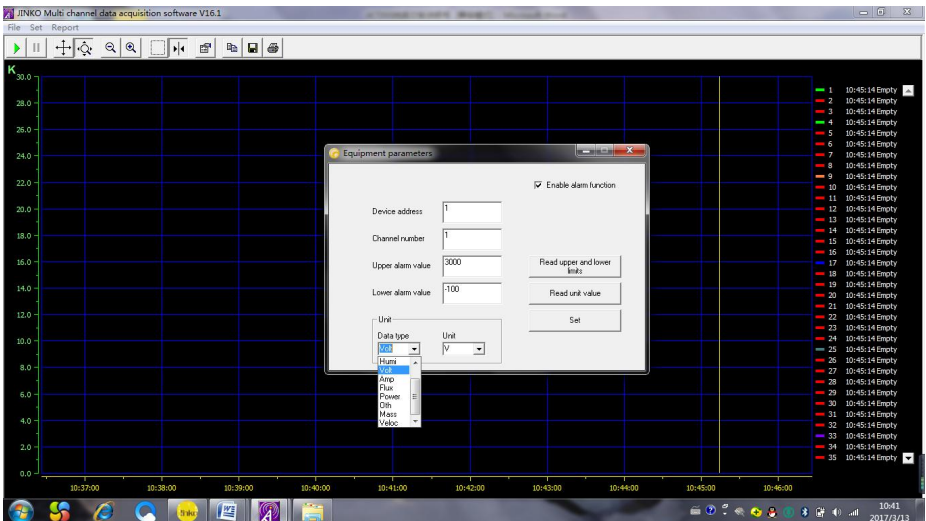

7-11 Alarm setting

7.4.1 Select contrast channel

7.4.1 Query and export of records of the contrast channel

Click on the main menu bar "data set" under the "Settings" option. It will pop up chart 7-12 interface in the interface, you need to select the query data, and then click save, display overview preview as shown in Figure 7-13.

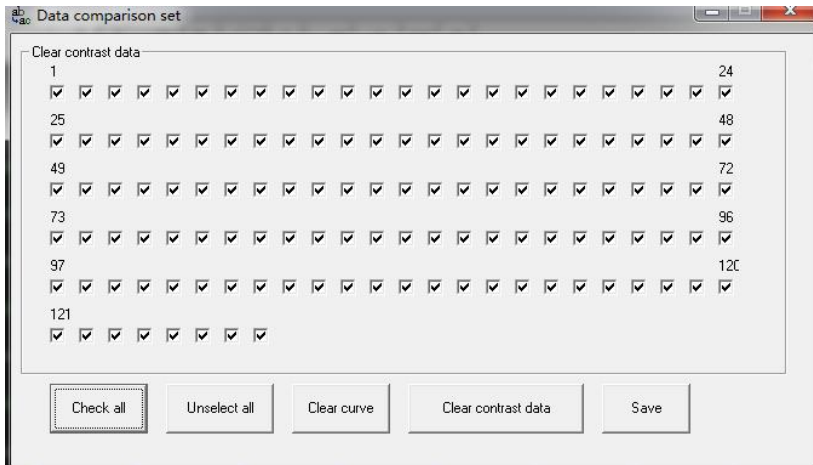

7-12 Contrast Channel

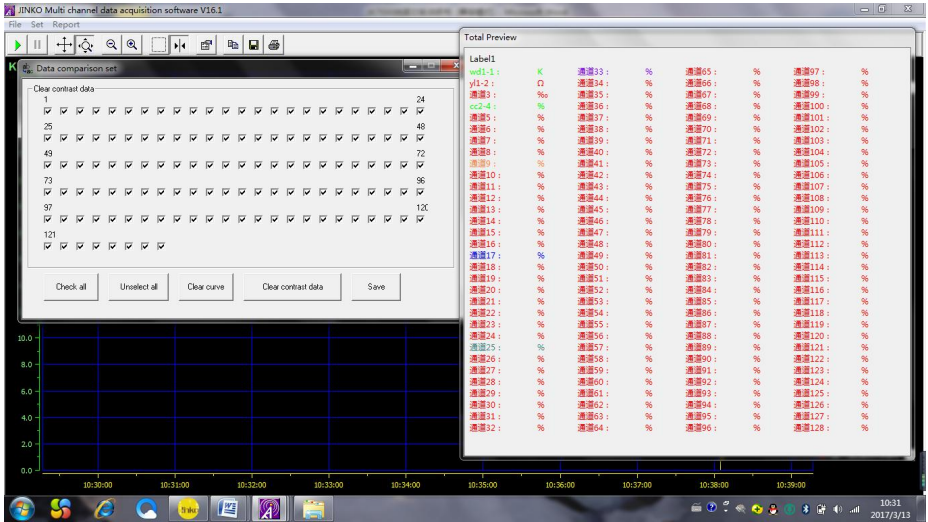

7-13 Overview preview

7.4.2 : Data from lower computer

The software supports reading data derived from lower computer. Click fast export data in the lower computer, after sampling, it will

generate a excel folder in the root directory of U disk. The file name can be defined.

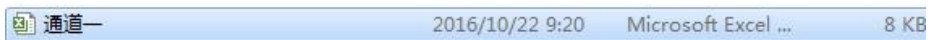

7.4.3 Historical curve data printing



Ways of printing historical data : back to 7-14 interface, click“ ”.

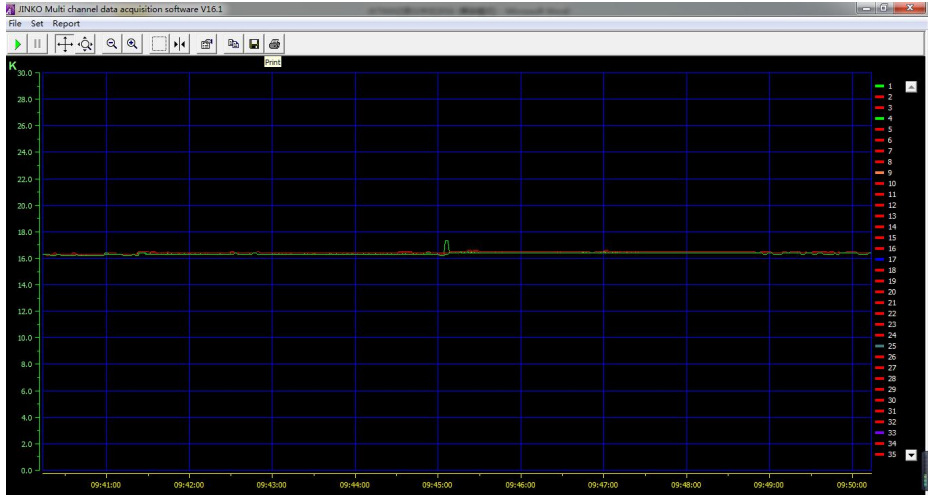

7-14 Print preview

Report printing

ID	Time	S1	S2	S3	S4	S5
1	340200	16.3	16.3	16.4	16.3	
2	340201	16.2	16.2	16.4	16.3	
3	340202	16.2	16.3	16.4	16.3	
4	340203	16.3	16.3	16.4	16.3	
5	340204	16.3	16.3	16.4	16.3	
6	340205	16.3	16.3	16.4	16.3	
7	340206	16.3	16.3	16.4	16.3	
8	340207	16.3	16.3	16.4	16.3	
9	340208	16.3	16.3	16.4	16.3	
10	340209	16.3	16.3	16.4	16.3	
11	340210	16.3	16.3	16.4	16.3	
12	340211	16.3	16.3	16.4	16.3	
13	340212	16.3	16.3	16.4	16.3	
14	340213	16.3	16.3	16.4	16.3	
15	340214	16.3	16.3	16.4	16.3	
16	340215	16.3	16.3	16.4	16.3	
17	340216	16.3	16.3	16.4	16.3	
18	340217	16.3	16.3	16.4	16.3	

7.5 Exit system

Way 1: Click “x” on the top right corner of the system 

Way 2: Click the "File (F)" on the main menu bar. Choose “Close”.

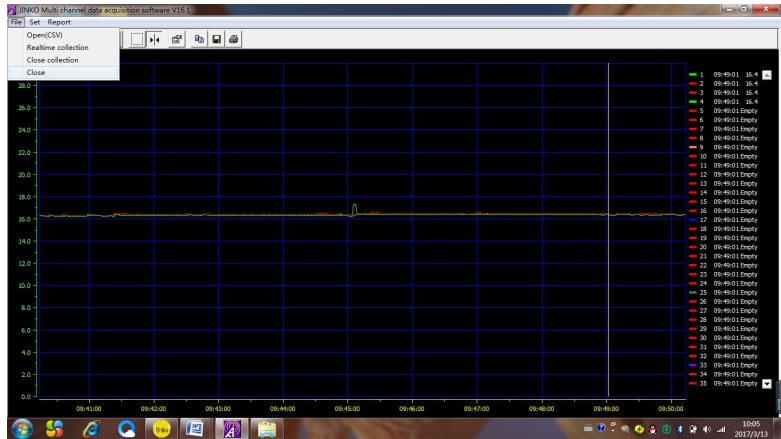

7-15 Exit system

Wireless transmission mode:

Support virtual serial port, the computer must have a wireless receiver and virtual serial port software. After installation, open the virtual software to add a serial port.



After setting, click “Yes”.

Factory settings of the instrument is wireless AP (TCP Server) mode,
wireless name: Jinko instrument
IP :192.168.11.254

If you connect laptop to the instrument, you need to change network connection to the **Jinko instrument** network so that it can achieve wireless communications

Open the temperature acquisition software. Change COM port to serial port in “settings” so that the print port can be equipped with printer model