

OPERATION MANUAL

Changzhou Jinailian Electronic Technology Co., Ltd

Address: No.C3,Building 22,New Impetus Pioneering Center,
No.1,Qingyang North Road,Tianning District,Changzhou,
Jiangsu,CN

TEL: 0086-519-85563477 Email: 5117jk17@163.com

Website: <https://jinailian.en.alibaba.com>

<http://www.jinko-tech.com>

7100Series precision pressure withstand / insulation tester

(JK7130/JK7132/JK7140/JK7142)

Operating instructions

Calibration and correction statement

Jin Ailian Electronics Co., Ltd. declares in particular that the instruments and equipment listed in this specification are in full conformity with the specifications and characteristics specified in our general catalogue. This instrument has been calibrated in our factory before leaving the factory. All instruments and equipment used in our company's calibration have been commissioned by the accredited Inspection Center for regular calibration. The procedures and procedures for calibration are in accordance with the specifications and standards of the electronic inspection center.

Product quality assurance

Jin'ai Lian Electronics Co., Ltd. guarantees that all the new machines manufactured and manufactured are subject to strict quality confirmation. At the same time, the company is willing to give free repairs to any defects or parts found in the factory within one year. However, if the user has to change the circuit, function, or repair machine and spare parts or box damage, the company does not provide free warranty services, maintenance fees may be charged according to the actual situation. If any abnormal condition occurs due to failure to connect all ground wires properly or to operate the machine according to safety regulations, we will not provide free warranty service.

Within a one-year warranty period, please send the malfunctioning unit back to our maintenance team or our designated distributor, the company will be properly repaired.

If the instrument is in abnormal use, or human negligence, or under the control of non-human failure, such as earthquakes, floods, riots, or fire and other non-controllable factors, the company will not give free warranty service.

Catalog

Chapter one	Brief	1
1.1	Safety Notes	1
1.2	technical terms	4
1.3	Installation preparation	7
1.4	Installation instructions	8
Chapter two	technical specification	9
2.1	Product specification	9
Chapter three	Front panel and rear panel	11
3.1	Front panel specification	11
3.2	Rear panel specification	13
Chapter four	Operation description	15
4.1	Test parameter setting	16
4.2	General parameter setting	25
4.3	Display message	30
4.4	Validation of test function	37
4.5	Operating procedure and steps	39
4.6	Continuous test of Withstand voltage / insulation tester and ground impedance tester	41
Chapter five	Interface description	42
5.1	Standard remote control interface(Remote I / O)	42
5.2	RS485 Interface (optional)	46
Chapter six	instrument calibration	49
6.1	Correction step	49
6.2	Correction completion	51

Chapter one Brief

High voltage test should pay attention to the provisions and matters!!!

1.1 Safety notice

- Before using this withstand voltage tester, please understand the use of this machine and related safety signs, in order to ensure safety.
- The Safety specifications cited in this instrument are those of Safety Class I (the airframe has earthing terminals for protection).
- Please select the correct input voltage (115V or 230V input) specification before switching on the input power switch.

Security symbol



careful signs. Warnings and attention notes listed in the reference manual to avoid injury to personnel or instrument damage.



Electric shock danger sign . High voltage may exist. Avoid contact.



Instrument grounding symbols.

WARNING! Warnings should be noted that the procedures, applications, or conditions performed are highly risky and may result in injury or even death.

CAUTION ! Be aware that any procedure, application, or condition performed may cause damage or loss of all stored data in the instrument.

The voltage and current generated by the withstand voltage tester are sufficient to cause injury or sensitization to personnel in order to prevent accidental injury or death. When moving and using the instrument, be sure to observe clearly before proceeding.

Maintenance and maintenance

User maintenance

Please do not lift the lid of the instrument to prevent the occurrence of electricity. All parts inside the instrument are absolutely free from user maintenance. If abnormal conditions occur, please seek the maintenance of JinAiLian electronics or its designated dealer. The attached lines and block diagrams are for reference only.

Regular maintenance

This withstand voltage tester, input power line, test line, and related accessories should be carefully inspected and calibrated at least once a year to protect the safety of users and the accuracy of the instrument.

User modification

Users are not allowed to alter the wiring or parts of the instrument on their own. If the instrument is altered, the guarantee of the instrument will automatically become invalid and the Company will not be responsible for any changes. It is not guaranteed to use parts or accessories that are not approved by JinAiLian Electronics. If the instrument is found to have been changed, JinAiLian Electronics will repair the circuit or parts of the instrument back to the original design state and charge a maintenance fee.

Test workstation

Working position

The location of the workstation must be arranged in a place that ordinary people do not have to go through, so that non-staff away from the workstation. If this is not possible because of the production line arrangement, the workstation must be separated from other facilities and marked "high-voltage test workstation". If the HV test station is very close to other operation stations, special attention must be paid to safety.

In high voltage test, danger must be marked. " During the high voltage test, please do not approach the staff."

Input power supply

The pressure tester must have good grounding, and the ground wire must be connected before operation, so as to ensure the safety of personnel. The power supply of the test station must be separately switched on and off, which should be marked at the conspicuous entrance of the test station so that everyone can identify it as the power switch of the test station. Once an emergency occurs, turn off the power immediately and then enter the processing accident.

Workplace

Use a non conductive material worktable as far as possible. No metal can be used between the operator and the tested substance. Position of operator shall not span the measured object operat or adjust pressure tester . If the volume of the object to be measured is very small, place the object to be measured as far as possible in a non-conductive box, such as acrylic box. The testing site must be kept neat and clean at any time. Instrument and test line not used Place a fixed position . Make sure that all personnel can immediately identify the objects being tested, the objects to be tested, and the objects to be measured.

The air around the test station should not contain flammable gases or use pressure testers beside flammable substances.

Operator requirements

Qualification of personnel Voltage and current output by the withstand voltage tester should be used and operated by trained personnel if it is sufficiently harmful or fatal to cause personal injury by misoperation of tactile electricity.

Code of safety

Operators must always be educated and trained to understand the importance of various operating rules and to operate the voltage tester in accordance with safety rules.

Dress code

Operators should not wear metal decorative clothes or wear metal ornaments and watches, etc., these metal ornaments can easily cause unexpected electrical. When the accident is electrifying, the consequences will be even more serious.

Medical regulations

The pressure tester must not be allowed to operate with heart disease or with a cardiac pacer.

Testing safety procedures

WARNING Never use a withstand voltage tester on a live circuit or device.

The grounding wire of the withstand voltage tester must be in accordance with the regulations. When connecting the test line, we must first connect the circuit [Return Lead] on the pressure tester to the tested object. Before testing, the high voltage test line can be inserted into the high voltage output terminal. When the high voltage test line is taken, it must be held at the insulator and must not be held on the conductor. The operator must make sure that the control switch and remote control switch of the withstand voltage tester can be completely controlled by himself. Remote control switch should be positioned when not in use, and must not be placed arbitrarily.

* [Because the voltage withstand device of JinAiLian must accurately measure the tiny leakage current. So the loop lines of some instruments are not directly grounded.] When testing, the tested substance must be completely insulated from the ground and the earth. If the object is contacted with the earth wire or the earth It may cause no measurement of current Or the current measured is inaccurate.

WARNING In the process of withstand voltage test, you must not touch the test items or Any object that has a connection with the object to be tested.

The following safety points must be noted.

- Non qualified operators and unrelated personnel should be kept away from the high voltage test area.
- Keep the high voltage test area in a safe and orderly manner at all times.
- In the high voltage test, you must not touch the test items or any objects connected with the tested objects.

- In case of any problems, turn off the high voltage output and input power immediately.
- After DC withstand voltage test, the discharge line must be properly discharged before dismantling the test line.

1.2 Technical language

Importance of testing ...

User safety

In today's world of high consumer awareness, every manufacturer of electrical and electronic products must do its utmost to ensure the safety of their products. The design of every product must be done as far as possible, so that users do not have any chance of injury. Even if the user is wrong, it should be safe. In order to meet the generally accepted safety requirements, the "withstand voltage testers" must be used. Pre safety enforcement unit, For example UL CSA IEC BSI VDE TU Vand JSI etc require Manufacturers to use "withstand voltage testers" as safety tests in the design and production of electronic or electrical products.

Withstand Voltage Test (Dielectric Withstand Voltage Test)

If a product can operate normally in a very harsh environment, you can be sure that it can also operate normally in a normal environment. The pressure test is often used as follows:

- Functional testing at design time - Determine the conditions for the designed product to meet its functional requirements.
- Specification test in production - Confirm that the products produced can meet the standards of their specifications.
- Product warranty confirmation test. - Confirm that the quality of products meets the safety standards.
- Safety testing after repair. - confirm that the product after repair can maintain compliance with safety standards.

Different products have different specifications. Basically, a voltage higher than the normal working voltage is added to the product during the withstand voltage test. This voltage must last for a specified period of time. If a component is within a specified time, its leakage current is also kept within the prescribed limits, it can be determined that the component is operating under normal conditions and should be very safe. Good design and good selection of insulation can protect the user from accidental electrical shock.

The withstand voltage test of this instrument is generally called "high voltage dielectric test" and abbreviated as "withstand voltage test". The basic requirement is to double the working voltage of the object to be measured, plus 1,000V, as the voltage standard for testing. The voltage of some products may be higher than 2X working voltage + 1000V. For example, some products have operating voltages ranging from 100V to 240V, and the test voltage of such products may be between 1000V to 4000V or higher. Generally speaking, products with a "double insulation" design may use a test voltage higher than the 2X operating voltage + 1000V standard.

Withstand voltage testing is more precise in product design and sample preparation than in formal production. Because the product has decided the safety of the product in the design test phase. Although only a small number of samples are used in product design, on-line testing during production requires that all products must pass safety standards to

ensure that no defective products will be aborted.

The output voltage of the withstand voltage tester must be kept within the range of 100% to 120% of the specified voltage. The output frequency of the AC withstand voltage tester must be maintained between 40 to 70 Hz, and the peak value of the AC withstand voltage tester shall not be less than 1.3 times of the RMS voltage value, and the peak value of the AC withstand voltage tester shall not be higher than 1.5 times of the RMS voltage value.

Advantages and disadvantages of AC (AC) test and DC (DC) test

Please first confirm with the safety unit specified by the product under test what voltage the product should use. Some products can accept both DC and AC test options, but there are still many products that are only allowed to accept one test in DC or AC.

If the safety code allows simultaneous DC or AC testing, the manufacturer can decide for itself which test is appropriate for the product. To achieve this goal, users must understand the merits and demerits of DC and AC tests.

Characteristics of AC withstand voltage (ACW) test

Most of the tested products will have some spurious electrical capacity.

These stray capacitors may not be fully filled by AC testing, and a persistent current will flow through them.

Advantages of AC withstand voltage (ACW) testing

1. Generally speaking, AC tests are easier to be accepted by safety regulatory units than DC tests. The main reason is that most products use alternating current, and alternating current testing can be used to test both positive and negative polarity of the product, and the product environment is completely consistent with the actual use of the situation.
2. Because the stray capacitors cannot be fully filled during AC testing, there will be no instantaneous impulse current, so the test voltage does not need to rise slowly. The full voltage can be added at the beginning of the test unless the product is sensitive to the impulse voltage.
3. Because AC testing can not fill those stray capacitors, there is no need to discharge the test object after testing, which is another advantage.

Disadvantages of AC testing

1. The main drawback is that if the stray capacitance of the object to be measured is very large or the object to be measured is capacitive load, the current generated will be far greater than the actual leakage current, so the actual leakage current can not be known.
2. Another drawback is the need to supply the current required for stray capacitance. The current output of the instrument is much larger than that of the DC test. This will increase the risk of operators.

Characteristics of DC (DC) testing

In DC withstand voltage test, the stray capacitance on the object to be tested will be filled, and the capacitive current caused by DC withstand voltage test will drop to zero after the stray capacitance is filled.

Advantages of DC testing

1. Once the stray capacitance on the tested substance is filled, Only the actual leakage current of the tested substance is left.

DC withstand voltage test can clearly show the actual leakage current of the tested substance.

2. Another advantage is that it only needs a short time to supply the charging current of the object to be measured, and the current required for other times is very small, so the current capacity of the instrument is much lower than the current capacity required for AC withstand voltage testing.

Disadvantages of DC testing

1. Unless there is no capacitance on the object to be tested, the test voltage must start from "zero" and rise slowly to avoid excessive charging current. The longer the slow rise time required for the larger capacitance, the lower the voltage that can be increased at one time. When the charging current is too large, it will cause the wrong judgment of the tester and make the test result incorrect.

2. Because the DC withstand voltage test will be charged to the object to be measured, so after the test, must treat the discharge of the object to do the next step.

3. Unlike AC testing, DC withstand voltage testing can only be carried out by a single polarity test, which must be considered if the product is to be used under AC voltage. This is also the reason why most safety regulation units recommend using AC voltage withstand test.

4. In AC withstand voltage test, the peak value of voltage is 1.4 times that of the meter, which is not shown by the ordinary ammeter, but also can not be achieved by the DC withstand voltage test. So most safety regulation units require DC withstand voltage test.

The test voltage must be increased to the same value. Only the withstand voltage test can detect the following conditions.

- The insulation strength of insulating materials is too weak.
- There are pinholes on insulators.
- The distance between components is not enough.
- The insulator is crushed and cracked.

1.3 Installation preparation

This chapter mainly introduces the rules of disassembly, inspection, pre-use preparation, storage and so on.

Unsealing and checking

JinAiLian Electronics products are packed in a foam-protected packaging box. If the packaging box is damaged when received, please check whether the appearance of the instrument is deformed, scratched, or damaged panel. If there is any damage, please inform JinAiLian Electronics or its dealers immediately. Please keep the packing box and foam in order to find out the reason. Our service center will help you repair or replace the new machine. Please do not return the product immediately before you notify the company or its distributor.

Preparation before use

Demand and choice of input voltage

The 71 series of voltage withstand tester uses 115V AC or 230V AC + 15% 47-63 Hz single phase power supply. Before switching on the power switch of the instrument, please make sure that the voltage selector switch on the backplane is in the correct position. At the same time, we must use the correct fuse, and the fuse has been marked on the backplane of the instrument. Before changing the fuse, the input power must be switched off to avoid danger.

Attention!!! The fuse used by this machine is 3.15A fast fuse.

Requirements for input power supply

WARNING Before connecting the input power, you must make sure that the ground wire on the power line is connected, and at the same time connect the ground wire to the earthing terminal on the airframe. The power plug on the instrument can only be plugged into the electrical socket with the ground wire. If the extension line is used, attention must be paid to whether the extension line is grounded.

The withstand voltage tester uses a three core cable. When the cable is inserted into the socket with ground wire, the grounding of the machine body has been completed.

environmental conditions

Temperature : 0°C-40°C (32°F-104°F).

Relative humidity: Between 20 and 80%.

height : It's below 2000 meters (6500 feet) above sea level.

Storage and transportation

Surrounding environment

The 71 series of pressure tester can be stored and transported under the following conditions:

Surrounding environment -40°C~ 75°C

Height 7620 meters (25000 feet)

This machine must avoid drastic changes in temperature, which may cause water vapor to condense in the body.

Packing method

Original packaging:

Please keep all the original packaging materials. If the instrument has to go back to the factory for repair, please use the original packaging materials. And please send all the accessories such as power cord and test line to the Maintenance Center of Jinai Lian Electronics. Please indicate the fault phenomenon and cause. In addition, please mark "fragile" on the package. Please handle it carefully.

Other packaging:

If no original packaging material can be found for packaging, please pack according to the

following instructions:

1. first use the bubble cloth or the dragon to wrap the instrument.
2. put the instrument in a multi-layer carton packaging that can withstand 150KG (350lb.).
3. The surroundings of the instrument must be filled with shock-proof material, about 70 to 100 mm thick (3 to 4 inch), and the panel of the instrument must be protected by thick cardboard first.
4. seal the box properly.
5. note "fragile goods" please handle with care.

1.4 Installation instructions

The 71 series of voltage tester of JinAiLian electronics does not require any additional field installation procedures.

Chapter two Technical specification

2.1 Product specification

MODEL	JK7130	JK7132	JK7140	JK7142
AC WITHSTAND VOLTAGE				
Output Rating	5KVAC/20mA			
	Range	Resolution	Accuracy	
Output Voltage, KVAC	0-5.00	0.01	± (2% of setting + 5V)	
Output Frequency	50Hz/60Hz ±100ppm, User Selection			
Output Waveform	Sine Wave ,THD.<2% (Resistive Load), Crest Factor = 1.3 - 1.5			
Output Regulation	± (1% of output + 5V), From no load to full load			
SETTINGS				
Max-Limit AC Current, mA	0 - 20.00	0.01	± (2% of setting + 2counts)	
Min-Limit AC Current, mA	0 - 9.999	0.001	± (2% of setting + 2counts)	
Ramp Up Time, second	0.1 - 999.9	0.1	± (0.1% + 0.05sec)	
Ramp Down Time, second	0-999.9	0.1		
Dwell Time, second	0.03-999.9 (0=continuous)	0.1		
Arc Detection	0, 1 - 9 ranges (0=OFF, 9 is the most sensitivity)			
DC WITHSTAND VOLTAGE (7140,7142 ONLY)				
Output Rating	6KVDC/7500μA			
Output Voltage, KVDC	0 - 6.00	0.01	± (2% of setting + 5V)	
Output Ripple	<5% (6KV/7500μA at Resistive Load)			
SETTINGS				
Max-Limit DC Current, μA	0 - 7500	1	± (2% of setting + 2counts)	
Min-Limit DC Current,	0 - 999.9	0.1	± (2% of setting + 2counts)	

μ A			
Ramp Up Time, second	0.1 - 999.9	0.1	$\pm (0.1\% + 0.05\text{sec})$
Ramp Down Time, second	0, 1.0 - 999.9	0.1	
Dwell Time, second	0, 0.4 - 999.9 (0=continuous)	0.1	
Arc Detection	0, 1 - 9 ranges (0=OFF, 9 is the most sensitivity)		
Discharge Time	< 200 msec		
INSULATION RESISTANCE (7132,7142 ONLY)			
Output Rating	1KVDC/9999M Ω		
Output Voltage, DCV	30 - 1000	10	$\pm (2\% \text{ of setting} + 5\text{V})$
SETTINGS			
Max-Limit Resistance, M Ω	0, 1 - 9999 (0=OFF)	1	$\pm (2\% \text{ of setting} + 2\text{counts})$ at 500-1000VDC, 1 -1000 M Ω $\pm (5\% \text{ of setting} + 2\text{counts})$ at 500-1000VDC, 1000 -9999 M Ω $\pm (8\% \text{ of setting} + 2\text{counts})$ at 30-500VDC, 1 -1000 M Ω
Min-Limit Resistance, M Ω	1 - 9999	1	
Ramp Up Time, second	0.1 - 999.9	0.1	
Ramp Down Time, second	0, 1.0 - 999.9	0.1	
Delay Time, second	0, 0.5 - 999.9 (0=continuous)	0.1	$\pm (0.1\% + 0.05\text{sec})$
MEASUREMENT			
AC/DC Voltage, KV	0 - 6.00	0.01	$\pm (1.5\% \text{ of reading} + 1\text{count})$
DC Voltage, V (IR only)	30 - 1000	1	$\pm (1.5\% \text{ of reading} + 5\text{V})$
AC Current, mA	0 - 3.500	0.001	$\pm (2\% \text{ of reading} + 2\text{counts})$
	3.00 - 20.00	0.01	
DC Current, μ A	0 - 350.0	0.1	$\pm (2\% \text{ of reading} + 2\text{counts})$
DC Current, mA	0.300 - 3.500	0.001	
Resistance, M Ω	1 - 9999 (Auto Range)	0.001	$\pm (2\% \text{ of setting} + 2\text{counts})$ at 500-1000VDC, 1 -1000 M Ω $\pm (5\% \text{ of setting} + 2\text{counts})$ at 500-1000VDC, 1000 -9999 M Ω $\pm (8\% \text{ of setting} + 2\text{counts})$
		0.01	
		0.1	
		1	

			at 30-500VDC, 1 -1000 MΩ
GENERAL			
Input Voltage AC	115/230Vac±15%, 50/60Hz ± 5%, Fuse 3.15A		
PLC Remote Control	Input : Test , Reset , Memory1.2.3 , Interlock Output : Pass , Fail , Processing , Reset-Out		
Interface(Optional)	RS485 Interface		
Memory	10 memories, 3 steps/memory		
Graphic Display	128×64 Graphic LCD		
Safety	Built-in Smart GFI circuit,GFI trip current 450μA max, HV shut down speed: <1mS		
Key Lock	To prevent unauthorized alteration of the test Parameters		
Calibration	Build-in software and external calibrated meters		
Verification	Build-in software driven verification menu to test fault detection circuits		
Alarm Volume Setting	Range: 0-9 ;0=OFF, 1 is softest volume, 9 is loudest volume.		
Environment	0-40°C, 20-80%RH		
Dimension/Net Weight	215mm(W)×89mm(H)×370mm(D)/10Kg		
STANDARD ACCESSORIES			
Power Cord(10A)	1		
Fuses	×2 (Including a spare contained in the fuse holder)		
Interlock Disable Key(1505)	1		
High Voltage Test Cable(1101)	1		
Return Test Cable(1102)	1		

Chapter three panels and backplanes

3.1 Front panel specification

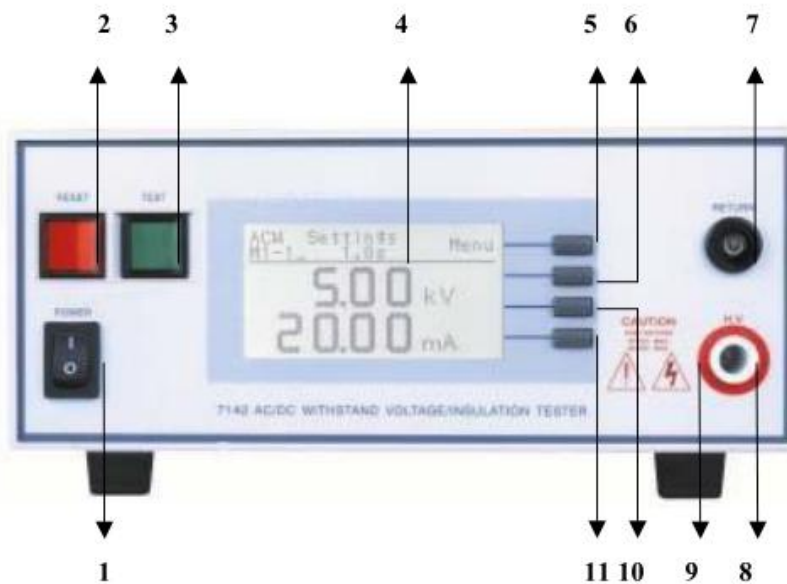

1. POWER Input power switch

Switches marked with international standard "1" (ON) and "0" (OFF) are used as input power switches.

2. RESET Switch

The red instantaneous contact switch also contains FAIL indicator. In setting mode, the function is the same as the EXIT key and can be used as a switch to leave the set mode. When the test is performed, the switch is used to turn off the alarm sound into the next state to be tested. In the process of testing, it can also be used as a switch for interrupt testing. The red indicator light will appear when the tested object fails to pass the test.

3. TEST Switch

The green instantaneous contact switch also contains PASS indicator as the starting switch for the test. When the tested object is passed, the green indicator light will shine.

4. LCD Display

128*64 backlit liquid crystal display, as a display to set data or test results display.

5. Menu/Result key

Operating keys for selecting entry mode and selection memory group, test items, AC or DC withstand voltage test and its parameter setting, insulation impedance test and its parameter setting, and function keys for input validation and function setting, as well as for inspecting test records, are also used as setting keys for keyboard locking.

6. Memory/Test key

Memory group selection keys can be selected from any of 10 memory groups to execute the test. The function key is selected as function mode selection and numeric parameter input in setting mode.

7. RETURN terminal

Loop terminal, is used in conjunction with the loop test line P/N 1102.

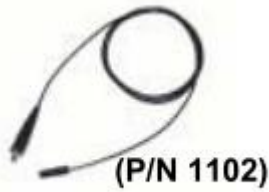

8. H. V. terminal

The high voltage output terminal, used in conjunction with the high voltage test line P/N 1101.



9. High voltage sign

When the instrument starts to output voltage, the indicator in the high voltage sign will flicker, indicating "High voltage outputting ,dangerous".

10. Step/System key

Test step selection keys, each memory group contains three test steps (STEP), can use STEP keys to arbitrarily select one of the steps, set the test parameters of this step, Selection keys for operating and environmental conditions, such as display contrast brightness, buzzer volume, remote or manual mode selection, and DUT test results display settings.

11. EXIT/ESCI key

As a function key to leave the set mode, if the input number is wrong, you can press the Esc key to clear the wrong number, and then re-enter the correct number, if the input number exceeds the scope of this analyzer specifications, the instrument will issue an alarm sound.

3.2 Rear panel description

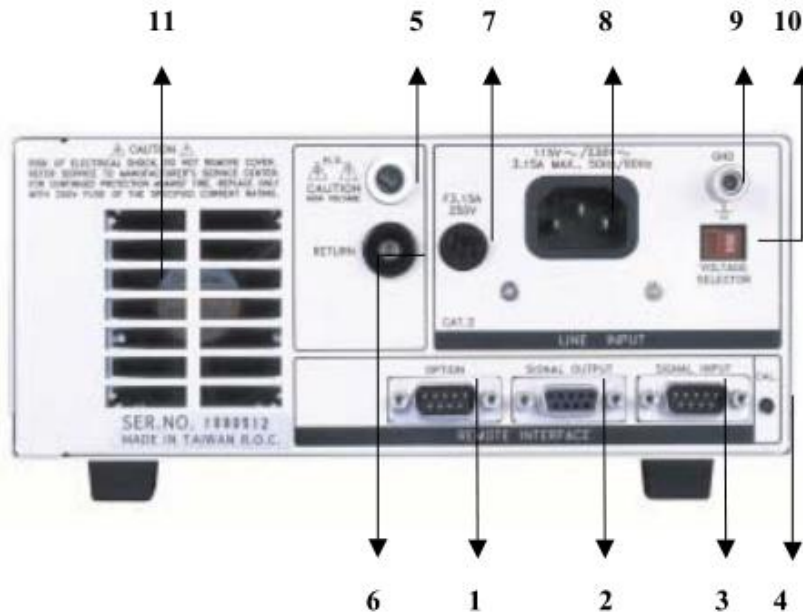

1. OPTION Terminal row

Provide a shopping interface RS485 (see Pag.47 for details).

2. SIGNAL OUTPUT Terminal row

Remote control signal output terminal row, type D (9PIN) terminal row block. Use relay (RELAY) contacts to output signals such as PASS, FAIL and PROCESSING. for remote control devices. (see Pag.44 for details).

3. SIGNAL INPUT Terminal row

Remote control signal input Terminal row, Type D (9PIN) terminal block, enter control signals for TEST and RESET, and select remote input signals that perform functions such as memory groups 1, 2, and 3. (see Pag.44 for details).

4. Correction key switch

To enter the calibration mode, we need to hold this switch first and then turn on the input power switch.

5. H. V. Terminal row

The high voltage output terminal is used in conjunction with the high voltage test line P/N 1101.



6. RETURN Terminal row

Loop terminal, is used in conjunction with the loop test line P/N 1102

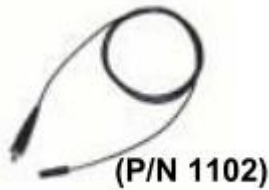

7. Input power fuse holder

Switch off the input switch before replacing the fuse and replace the standard fuse.

8. Input Power outlet

The standard IEC 320 power socket can accept the standard NEMA power plug.

9. Earthing (EARTH) terminals

The grounding terminal of the body must be connected to the ground to ensure the safety of the operator.

10. Input voltage selector switch

Select the input power supply voltage, the switch to the left is 115V, the switch to the right is 230V, the instrument is set at 230V when the factory.

11. Heat dissipating fan

Continuously run the exhaust fan, please keep the rear panel good exhaust heat dissipation space.

Chapter four explains the operation

The 71 series of withstand voltage testers are equipped with the function of link locking, so check whether the keyboard is locked before entering the parameter setting. After pressing the Test key, if the instrument is locked, there will be two short beeps and the display will also display:

As shown in the picture



Then came back to the original picture. Therefore, the lock must be released before the test can be carried out. Please install the unlocking device and remove the locking of the link.

The 71 series of withstand voltage testers also have a keyboard lock function, to enter the parameter setting, you need to check whether the keyboard is locked. After pressing the Menu key, if the keyboard of the instrument is locked after entering the parameter setting screen, two short beeps will be issued and the display will display: As shown in the picture



Then came back to the original picture. Therefore, we must first unlock before testing parameters can be set. Please refer to the instructions for keyboard locking to unlock the keyboard.

The "Menu" key is the operation key to enter the parameter setting mode. When entering the home directory setting mode, you can select the Menu, Memory, Step and Exit functions. Pressing the Menu key once again will enter the next sub-directory mode. At the same time, the set test parameters will be automatically stored in memory. Test parameters or modes stored in memory are retained after power is switched off and will not be removed unless they are artificially reset, As shown in the picture

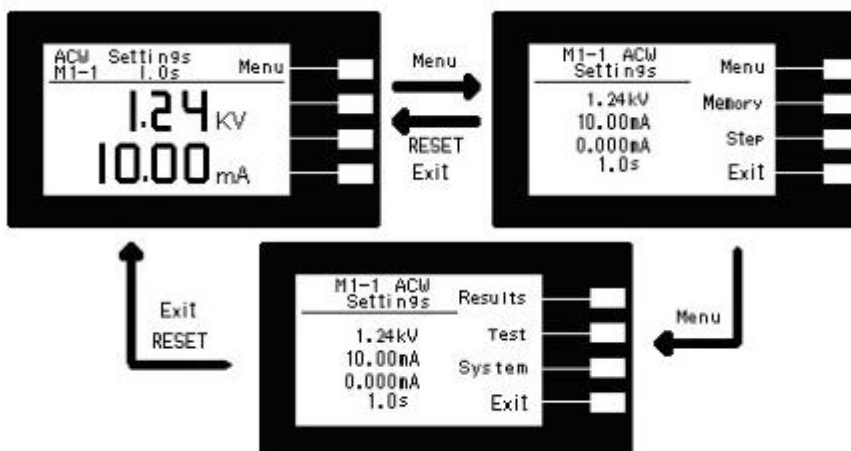

Rotate to the last test parameter setting item and then go back to the first parameter setting item. However, the rotational parameter items will vary according to the selected parameters set to AC withstand voltage test, DC withstand voltage test or insulation impedance test. The program will provide different parameter setting items according to different items.

In the process of test parameter setting, if it is not necessary to reset all the test parameters, you can press the "EXIT" key to leave the test parameter setting mode after any step is completed, the program will automatically enter the test mode, and the test parameters have been set into memory.

The program does not accept unreasonable settings and inputs. If there are unreasonable settings or inputs, two short beeps will be issued and returned to the original settings.

4.1 Test parameter setting

Memory key

Ten test program memory groups (MEMORY) have three test steps (STEPS), each of which can be sequentially linked to the next test program memory group's test steps. But each test step can only set one test function. The following table shows the description of each test program memory group and the function settings of each test step.

MEMORY 0	STEP 1	STEP 2	STEP 3
Only one test function can be selected for each test step.	ACW DCW IR	ACW DCW IR	ACW DCW IR
MEMORY 2	STEP 1	STEP 2	STEP 3
Only one test function can be selected for each test step.	ACW DCW IR	ACW DCW IR	ACW DCW IR
....			
MEMORY 9	STEP 1	STEP 2	STEP 3
Only one test function can be selected for each test step.	ACW DCW IR	ACW DCW IR	ACW DCW IR

Annotation:1. On the 7130 and 7140 models, there is no insulation impedance IR test function, nor will there be set keys and parameters for this function on the instrument.

2. Press Memory to proceed to the next memory group in sequence, and after the ninth test step, back to step 0.

Step key

After pressing the STEP key, the LCD display will display the test parameters of the test items set by this step, that is, AC voltage, DC voltage, insulation impedance test parameters. Press the STEP key again, and then proceed to the next test step in sequence. After the third test step, you go back to the first step.

When the test step is linked to the next test step, LCD display will display a “_”After the representative number of steps,For example, after the first test step of the first memory group, the second test step of the first memory group is automatically linked, as shown in the figure.

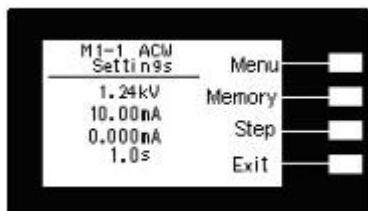

EXIT key is used as the function key to leave the set mode.

Test key

After pressing the Test key, enter the voltage test parameter setting mode, and the LCD display is displayed.As shown in the picture

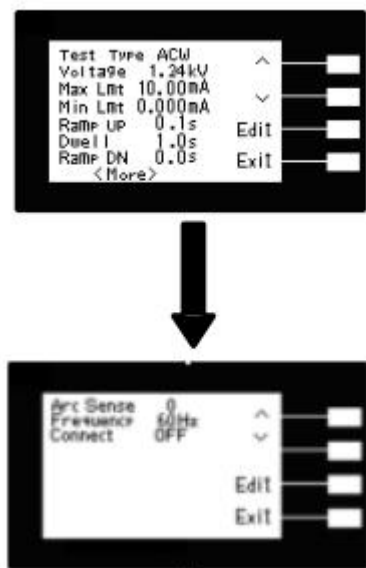

Test Type XXX : Pressure test item setting mode

Voltage X.XXkV : Test voltage setting (unit:10V) Max Lmt

XX.XXmA :Upper limit setting.

Min Lmt X.XXX mA :Lower limit setting.

Ramp UP X.Xs: Ramp time setting, (unit: 0.1 sec/step)

Dwell X.Xs: Test time parameter setting. (unit: 0.1 sec/step)

Ramp DN X.Xs:Ramp down time setting (unit: 0.1 sec/step)

Arc Sense X :Arc sensitivity (0-9) setting

Frequency XXHz: Output frequency setting, 50 or 60 Hz)

Connect ON/OFF: Step connect setting.

Notes : 1.X is numbers (0~9)

2.Press the Edit key to enter the edit key of all the test parameters.

Withstand Voltage test parameter setting

The setting of the withstand voltage test parameter is the operation key of selecting the parameter item by using the ^ key or the v key. Enter the next parameter item at each click. The pressure test parameter setting project is as follows: Test Type (Test Type), Voltage (Voltage), Upper limit of current (Max Lmt), Lower current limit (Min Lmt), ramp up time (Ramp UP), test time (Dwell Time), ramp down time (Ramp DN), Arc sensitivity (ARC Sense), Frequency (Frequency) (DC withstand voltage test does not have this item.), Step link (Connect).

Selection of test items (Test Type)

Please select the items to be tested with the '+' or '-' keys. The instrument is equipped with three test items: AC withstand voltage test (ACW), DC withstand voltage test (DCW), insulation impedance test (IR), and so on. As shown in the picture The test items available for different models will vary. The following table is a comparison of the test items available for each model:

Model	Selectable test project
7130	ACW
7132	ACW、 IR
7140	ACW、 DCW
7142	ACW、 DCW、 IR

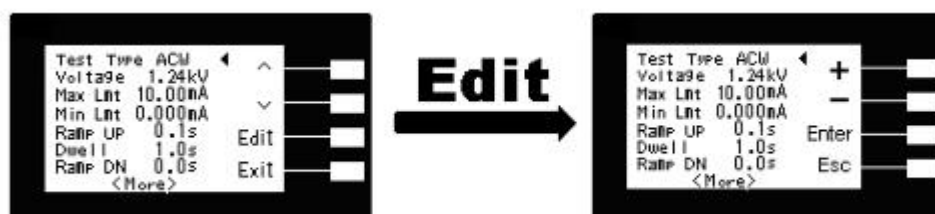

Output voltage (Voltage) setting

Please use the ^ or v button on the panel to move to the voltage gear and then press the Edit key, The program will enter the output voltage setting mode of the withstand voltage test. Please input the output voltage to be set by the "+" or "-" keys on the panel, and then press ENTER to save the set value. unit is "KV", As shown in the picture



Upper limit of leakage current (Max Lmt) setting

Please use the ^ or v button on the panel to move to the Max Lmt gear and then press the Edit key, The program will enter the current leakage limit setting mode. Please use the

"+" or "-" keys on the panel to input the current leakage limit value to be set for the output AC or DC withstand voltage test.and then press ENTER to save the set value, unit is“mA”, As shown in the picture

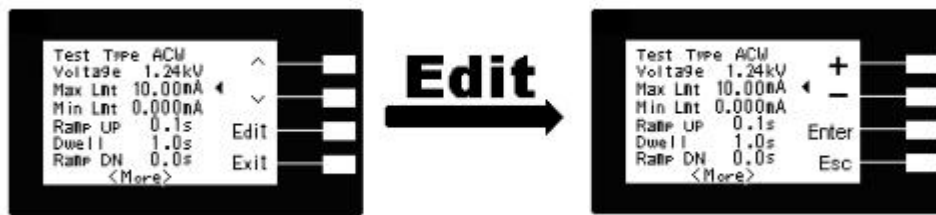

leakage current lower limit(Min Lmt)setting

Please use the“^”or“v” button on the panel to move to the Min Lmt gear and then press the Edit key,The program will enter the lower limit of leakage current setting mode. Please input the lower limit of leakage current for output AC or DC withstand voltage test by using the "+" or "-" keys on the panel.,and then press ENTER to save the set value, unit is“mA”,As shown in the picture



Ramp Up time (Ramp Up)setting

Please use the“^”or“v” button on the panel to move to the Ramp Up gear and then press the Edit key, The program will enter the slow rise time setting mode. Please input the slow rise time value of the output AC or DC withstand voltage test to be set by the "+" or "-" keys on the panel.and then press ENTER to save the set value, unit is“s” ,As shown in the picture



Test time (Dwell) setting

Please use the“^”or“v” button on the panel to move to the Dwell gear and then press the Edit key.The program will enter test time setting mode. Please use the "+" or "-" keys on the panel to input the test time value of the output AC or DC withstand voltage test to be

set.and then press ENTER to save the set value, unit is“s” ,As shown in the picture



Raamp down time (Ramp DN)setting

Please use the“^"or“v"” button on the panel to move to the Ramp DN gear and then press the Edit key,The program will enter the slow-down time setting mode. Please input the slow-down time value of the output AC or DC withstand voltage test to be set by the “+” or “-” keys on the panel.and then press ENTER to save the set value, unit is“s” ,As shown in the picture

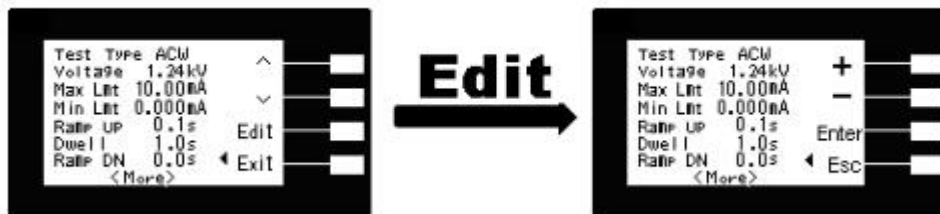

Arc sensitivity (Arc Sense) setting

Please use the“^"or“v"” button on the panel to move to the Arc Sense gear and then press the Edit key,The program will enter the Arc sensitivity setting mode. Please input the sensitivity of the input arc with the “+” or “-” key on the panel.(there are 0 to 9 paragraphs).and then press ENTER to save the set value,9, the sensitivity is the highest, while “0” does not detect the arc condition of the tested substance.As shown in the picture



Arc detection sensitivity setting	Level 9	2.8 mAp
	Level 8	5.5 mAp
	Level 7	7.7 mAp
	Level 6	10 mAp
	Level 5	12 mAp
	Level4	14 mAp
	Level 3	16 mAp
	Level 2	18 mAp
	Level1	20 mAp

	Set range: 1 ~ 9	Set range: 2 ~ 20mAp
--	------------------	----------------------

Output frequency (Frequency) setting

Please use the "∧" or "∨" button on the panel to move to the Frequency and then press the Edit key. The program will enter the output frequency setting mode. Use the '+' or '-' keys on the panel to input the output frequency of the output AC or DC withstand voltage test you want to set. Select to switch the output frequency to 50 or 60 Hz., and then press ENTER to save the set value. As shown in the picture (This function is only AC voltage withstand.)



Step Connect (Connect) setting

Please use the "∧" or "∨" button on the panel to move to the Connect and then press the Edit key. The program will proceed to Step connect Settings mode. Use the '+' or '-' keys on the panel to enter the step connect for the output AC or DC withstand voltage tests to be set and select ON or OFF. Then press the ENTER key to store the set value. If the step connect is set to ON, it will automatically connect to the next step to continue the test after the step test is completed. If set to OFF, the test will stop immediately after the test is completed in this step and will not continue to the next test step. As shown in the picture



This is the last step to set the test parameters. You can press Exit key to go back to the program memory group parameter setting step to check whether the test parameters are wrong or press "EXIT" key to leave the test parameters setting mode and enter the test mode to prepare for the formal test.

Insulation impedance test parameters (IR) setting

Parameter setting of insulation impedance test is also used "∧" or "∨" as the operation key of selecting item of parameter. Enter the next parameter item at each click. The withstand voltage test parameter setting project is in order: test item (Test Type), voltage (Voltage), Upper limit of insulation impedance (Max Lmt), Insulation impedance lower limit (Min Lmt), ramp up time (Ramp UP), Delay decision time (Delay), ramp down time

(Ramp DN),step connect (Connect)。

Test item (Test Type)select

Please use the "+" or "-" key to select the items to be tested. This instrument has three kinds of test items: AC withstand voltage test (ACW), DC withstand voltage test (DCW), insulation impedance test (IR), and so on. The test items available for different models vary, and the table below is a comparison of the test items available for each model.

Mdoel	Selectable test project
7130	ACW
7132	ACW、 IR
7140	ACW、 DCW
7142	ACW、 DCW、 IR



Test key

After pressing the Test key, the pressure test parameter setting mode is entered, and the LCD display is displayed.As shown in the picture



Test Type xxx : Insulation impedance test item setting mode

Voltage X.XXkV : Test voltage setting (unit: 1V)

Max Lmt X MΩ : The upper limit of insulation impedance is set.

Min Lmt XX MΩ: The lower limit of insulation impedance is set.

Ramp UP X.Xs: Ramp time setting (unit:0.1sec/step)。

Delay X.Xs: Delay decision time parameter setting,(unit : 0.1 sec/step)。

Ramp DN X.Xs: Ramp down time Setting,(unit : 0.1 sec/step)。

Connect ON/OFF: step connect setiing .

Notes : 1.X is number (0~9) .

2.Press the Edit key to enter the edit key of all the test parameters.

Output voltage (Voltage) setting

Please use the "▲" or "▼" button on the panel to move to the voltage and then press the Edit key. The program will enter the output voltage setting mode of the insulation impedance test. Please input the output voltage to be set with the "+" or "-" keys on the panel. Then press the ENTER key to store the set value. unit is (unit is 1 Volt/step), As shown in the picture



Upper limit of insulation impedance(Max Lmt) setting

Please use the "▲" or "▼" button on the panel to move to the Max Lmt and then press the Edit key. The program will enter the insulation impedance upper limit setting mode. Please enter the insulation impedance upper limit with the "+" or "-" keys on the panel. (unit is 1 M Ω /step), Then press the ENTER key to store the set value. If the upper limit of insulation impedance is not determined, the parameter of this function must be set to 0., As shown in the picture



Insulation impedance lower limit(Min Lmt) setting

Please use the "▲" or "▼" button on the panel to move to the Min Lmt and then press the Edit key. The program will enter the setting mode of the lower limit of the insulation impedance. Please enter the lower limit of the insulation impedance with the "+" or "-" keys on the panel. (unit is 1M Ω /step), Then press the ENTER key to store the set value. As shown in the picture



ramp up time(Ramp Up) setting

Please use the "▲" or "▼" button on the panel to move to the Ramp Up and then press the Edit key. The program will enter the Ramp Up time setting mode. Please input the Ramp

Up time value of the output insulation impedance test to be set by the "+" or "-" keys on the panel. Then press the ENTER key to store the set value. unit is "s". As shown in the picture



Determination of delay time (Delay) setting

Please use the "∧" or "∨" button on the panel to move to the Delay and then press the Edit key. The program will enter the decision delay setting mode. Please enter the decision delay value with the "+" or "-" keys on the panel. (unit is 0.1sec/step). Then press the ENTER key to store the set value. The determination of the delay time setting is used as the basis for determining the upper and lower limits of the insulation impedance of the analyzer. Because most of the objects under test are Capacitive and produce a large charge current, judging the delay time can let the analyzer make a judgment after the charge current is stable. The determination of the delay time must be based on the capacitance of the measured object and the accuracy of the insulation impedance as a reference and basis for setting. As shown in the picture



Rame down time (Ramp DN) setting

Please use the "∧" or "∨" button on the panel to move to the Ramp DN and then press the Edit key. The program will enter the slow-down time setting mode. Please input the slow-down time value of the output insulation impedance test to be set with the "+" or "-" keys on the panel. Then press the ENTER key to store the set value. unit is "s". As shown in the picture



Setp connect (Connect)setting

Please use the "∧" or "∨" button on the panel to move to the Connect and then press the Edit key ,The program will proceed to Step connect Setting mode. Please use the "+" or "-" keys on the panel to enter the step connect for the output insulation impedance test to be set and select ON or OFF. Then press the ENTER key to store the set value, If the step connect is set to ON, it will automatically link to the next step to continue the test after the step test is completed. If set to OFF, the test will stop immediately after the test is completed in this step and will not continue to the next test step. As shown in the picture



This is the last step to set the insulation impedance test parameter (Test). Press Exit key to go back to the program memory group parameter setting step to check whether the test parameter is wrong. If there is an error, correct the wrong part according to the program, or press the "EXIT" key to leave the test parameter setting mode and enter the test. Mode, prepare for formal insulation impedance test.

4.2 General parameter setting

General parameter setting key

Use the System key to select the operation key for general parameter items. Click the "∨" key button and turn to the next parameter item. In sequence are PLC Remote (PLC Remote), Single step link test(Single Step), Alarm volume(Alarm), LCD contrast brightness (Contrast), Test result selection(Results), Keypad lock(Lock), Program memory group lock(Mem Lock), Grounding interruption stop(Smart GFI), After turning to the last item, it will turn to the first item and start anew.

The system parameters of these instruments are the general setting conditions on the instrument during testing, and are not related to the functional parameters of the instrument. The storage positions of these system parameters are also completely separated from the functional parameters , As shown in the picture



System key

After pressing the System key, it enters the general parameter setting mode, and the LCD display is shown above.

PLC Remote ON/OFF : PLC Remote control
 Single Step ON/OFF :Single step link test
 AlarmX : Alarm volume
 Contrast X :LCD contrast brightness
 Results All/Last P/F : Test result selection
 Lock ON/OFF : Keypad lock
 Mem Lock ON/OFF : Program memory group lock
 Smart GFI ON/OFF : Grounding interruption stop
 Cal Alert ON/OFF: Check prompt message
 Cal Date XX/XX/XX: Date of factory verification
 Cal Due XX/XX/XX: Next calibration cycle date
 Alert XX/XX/XX: Check prompt date
 Date dmy XX/XX/XX: Present date
 Time XX:XX AM/PM: Present time

- Notes :
- 1.X is numbers (0~9) .
 - 2.Press the "√" key to enter the edit key of all the test parameters.
 - 3."+" key input select 0-9 or switch ON/OFF or Last, All, P/F
 4. Exit is the Exit key.

PLC remote control (PLC Remote)

Please use the "√"key on the panel to move to the PLC Remote gear and press the "+" key input to select ON or OFF.If the PLC remote control is set to ON, the test start-up function of the analyzer must be controlled by the remote control terminal of the instrument backplane. The TEST switch on the panel will not work, while the RESET switch remains operational and unaffected.If the PLC remote control is set to OFF, the test operation function of the analyzer is entirely operated by the TEST switch and RESET switch on the panel, but the remote control RESET on the backplane is still valid.As shown in the picture

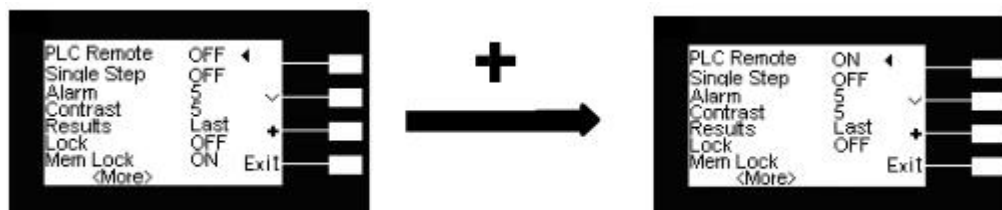

Single Step connect test(Single Step)

Please use the "√"key on the panel to move to the Single Step gear and press the "+" key input to select ON or OFF.if Single Step control is set to ON,The analyzer performs steps when connecting test,When the first set of step tests is completed, the next set of step tests will be executed by pressing the TEST switch again. For example, the single step remote control is set to OFF.The analyzer performs steps when connecting test. When the first set of step tests is completed, the next set of step tests will be automatically linked.As

shown in the picture

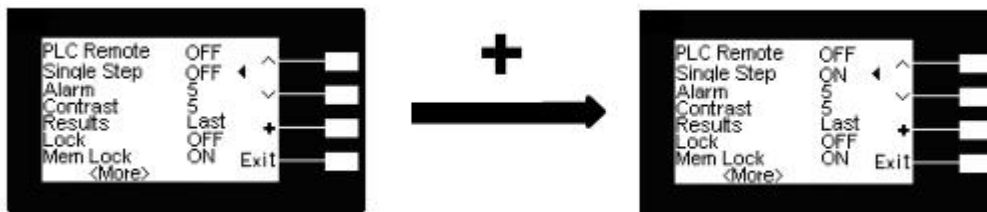

Alarm volume(Alarm)

Please use the "∨"key on the panel to move to the Alarm gear and press the "+" key input to select 0 ~ 9, 0 is used to turn off the alarm sounds, the 1 volume is the smallest, and the 9 is the maximum. Input the number of alarm volume with the number key, the program will immediately change the alarm volume settings, and issue the set volume. When the alarm volume setting is completed, the program automatically stores the alarm volume number set into the memory program. As shown in the picture

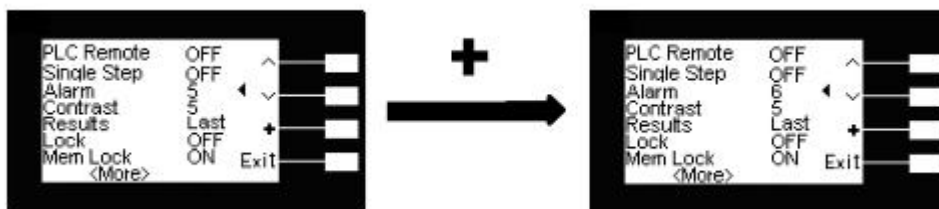

LCD Contrast brightness(Contrast)

Please use the "∨"key on the panel to move to the Contrast gear and press the "+" key input to select 1 ~ 9, The display immediately changes the contrast brightness of the LCD for immediate inspection of the brightness of the contrast. If you need to modify the contrast brightness, you can modify it directly. After the LCD contrast brightness setting is completed, the program will automatically save the set contrast brightness number into the memory program. LCD contrast brightness setting is 1 ~ 9, 1 is the contrast brightness is the weakest, and 9 is the contrast brightness is strongest. As shown in the picture

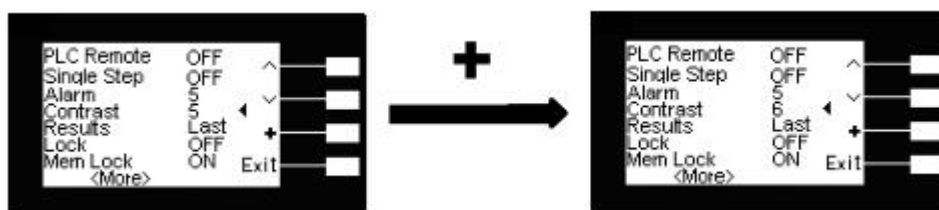

Test result selection (Results)

Please use the "∨"key on the panel to move to the Results gear and press the "+" key input to select All or Last or P/F, As shown in the picture, All displays three test results simultaneously in LCD, and Last displays a single test result in LCD, P/F Display two test results of PASS or FAIL in LCD.

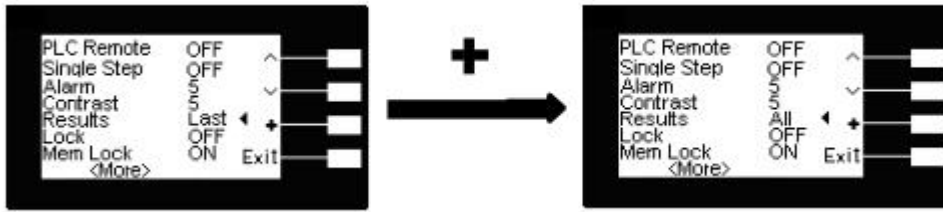

Keypad lock (Lock)

Please use the "∨"key on the panel to move to the Lockgear and press the" +" key input to ON or OFF. The locking and unlocking procedures are as follows:

1. Press the Menu button on the front panel first, then turn on the input power switch of the instrument. After opening the power button, after a short time, the program will automatically enter the boot mode, Press the "Menu" button twice to enter the parameter setting mode. Press the System button to enter the general parameter items., Please use the "∨"key on the panel to move to the Lockgear and press the" +" key input to ON or OFF.
2. If you want to change the lock mode from "ON" to "OFF", turn off the input power switch of this instrument, and then boot up according to the above program, the program will automatically change the lock mode.
3. After setting up, the setting parameters will be automatically stored in the memory body without any other keys.
4. When the keyboard is locked, all the keys (including the call memory group) on the panel except the TEST and RESET switches are locked and can not be operated. As shown in the picture

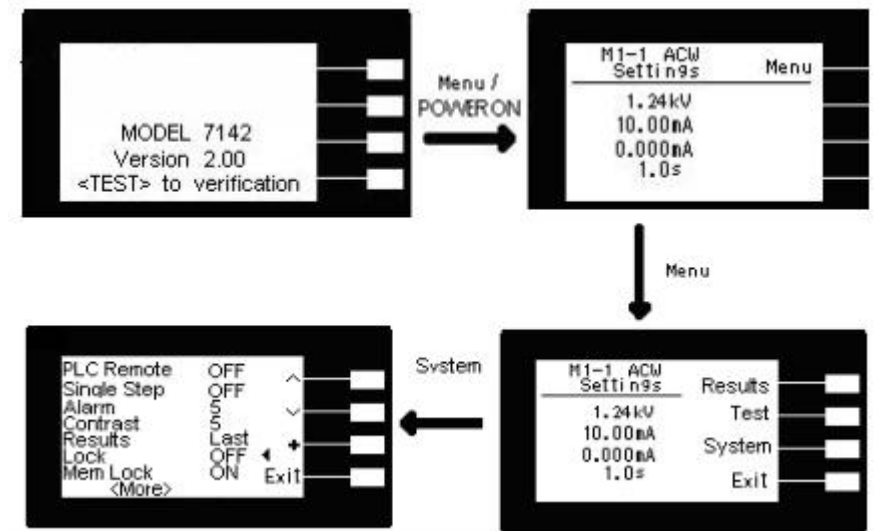

Program memory group lock(Mem Lock)

Please use the "∨"key on the panel to move to the Mem Lock gear and press the" +" key input to select ON or OFF. if Mem Lock is set ON, When the keyboard is locked, The program memory group (Memory) is locked and cannot be called. If the program memory locking function is selected as "OFF", the program memory group can still be called when the keyboard is locked, but the test parameters can not be changed. The difference

between the keyboard and the keyboard is not locked. Can only call test parameters set in program memory group. The keyboard locking function has been pre selected as "ON" at the factory. As shown in the picture

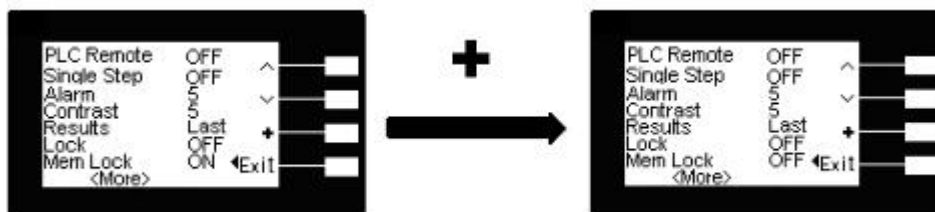

Grounding interruption stop (Smart GFI)

Grounding interruption stop(Smart GFI) It is a kind of protective device designed to prevent the operator from contacting the high voltage circuit and causing electric shock. It can directly measure the current of the ground wire, so as to avoid wrong judgment and misoperation caused by position swing. Please use the "∨" key on the panel to move to the Smart GFI gear and press the "+" key to enter and select ON or OFF.

If Smart GFI setting as ON Smart GFI It automatically detects the line of high voltage to Return or high voltage to earth. If it is a high voltage line to the earth, detects the high-voltage current flowing through the ground > 450 A, the GFI will act, and the output will be cut off within 1 mS to stop the test. If Smart GFI is set to OFF, there is no such function, but it can still be tested as shown below

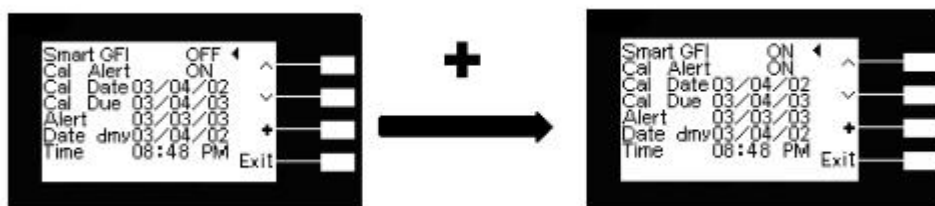

This is the last step of the general parameter setting (system) setting, you can directly press the "EXIT" key to leave the test parameter setting mode, and enter the test mode, ready to formally carry out the voltage test.

Check prompt message(Cal Alert)

Use the "∨" key on the panel to move to the Cal Alert gear and press the "+" key to enter and select ON or OFF. As shown in the picture

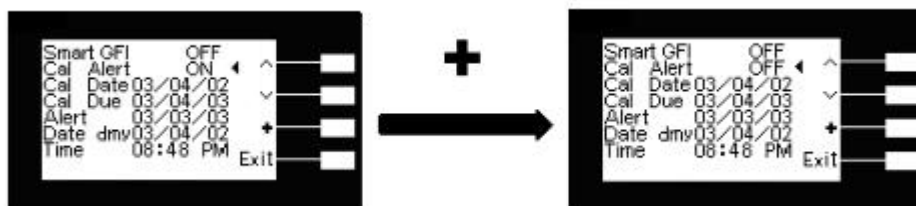

If Cal Alert is set to ON, when the analyzer is to be calibrated, the sub-analyzer will display

a prompt screen at each boot to inform the user that the calibration date of the analyzer has arrived. As shown in the picture, if Cal Alert is set to OFF, no such function is available.

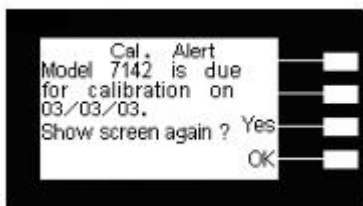

Date of factory calibration(Cal Date)

Use the "∨" key on the panel to move to the Cal Date gear and press ">" to select the field you want to modify. Press "+" to make the modification. As shown in the picture

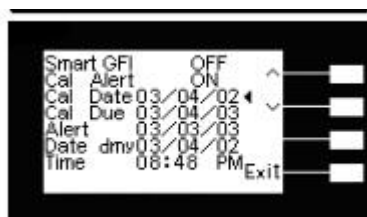

(Note: This function is the date of factory calibration. General users can not modify it. If necessary, please contact our engineers).

Next calibration cycle date (Cal Due)

Use the "∨" key on the panel to move to the Cal Date gear and press ">" to select the field you want to modify. Press "+" to make the modification. As shown in the picture (Note: this function can be modified according to the needs of different companies. The original set is one year).

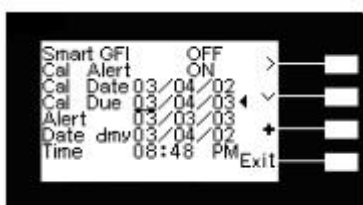

Check prompt date(Alert)

Use the "∨" key on the panel to move to the Cal Date gear and press ">" to select the field you want to modify. Press "+" to make the modification. As shown in the picture (Note: The default value of this function will be one month earlier than the date of the next calibration cycle, which can be modified according to the requirements of each company).

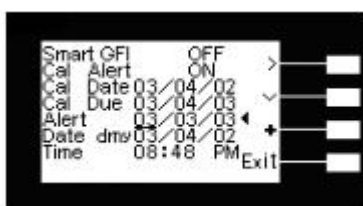

Now date (Date)

Use the “∨”key on the panel to move to the Date gear and press “>” to select the field you want to modify. Press the “+” key to make the modification. There are two formats for the date display, one is day, month, year and the other is month, day and year. As shown in the picture

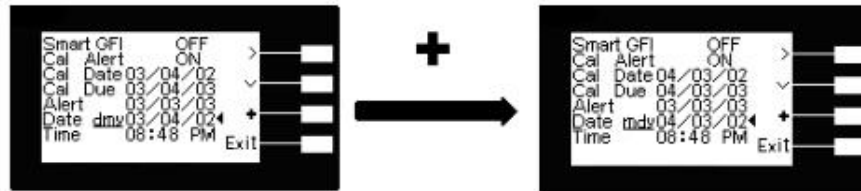

Now time (Time)

Use the key on the panel to move ‘∨’to the Time gear and press ‘>’ to select the field you want to modify. Press the + key to make the modification. As shown in the picture



4.3 Display message

The following is a variety of messages that will appear on the LCD monitor during the execution of the test. If the memory group "MX" on the display is followed by "_" (that is, "MX_"), this test is either a withstand voltage and insulation connection test or an insulation and withstand voltage connection test. The display message for single function test is shown below.

The display information for AC and DC withstand voltage tests is roughly the same, except that "AC" or "DC" are added to the unit of voltage to distinguish between AC and DC withstand voltage tests.

4.3.1 AC withstand voltage test

Test abort (Abort)

If the AC withstand voltage test is in progress and the test is interrupted by pressing RESET switch or using remote control, the LCD display will display ACW Abort. As shown in the picture



Ramp Up test (Ramp Up)

If the AC withstand voltage test has a Ramp Up test program, the test results will be updated continuously before the analyzer reads the first test results. The LCD display will display ACW Ramp Up. As shown in the picture

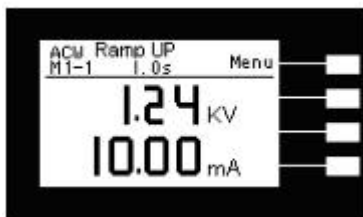

Ramp down (Ramp DN)

If the AC withstand voltage test is set, there is a Ramp down (Ramp DN) test procedure. Before the analyzer reads the first test result, the LCD displays DCW Ramp DN. As shown in the picture



Test time (Dwell) The results of AC withstand voltage tests are updated continuously, and the LCD display displays ACWDwell before the analyzer reads the first test result. As shown in the picture



The upper limit of leakage current (Max Lmt) If the leakage current of the object under test exceeds the set value of the upper limit When doing AC voltage test, it will be judged by the program as the test failure caused by the upper limit of leakage current. The LCD

display will display Max-Fail.As shown in the picture



Short (Short)

If the tested object is doing AC voltage withstand test,The leakage current is far beyond the range that can be measured by the analyzer, and the special short circuit circuit judging circuit action of the analyzer is added.It will be judged by the program as a test failure caused by a short circuit.LCD the LCD display displays ACW Short,As shown in the picture

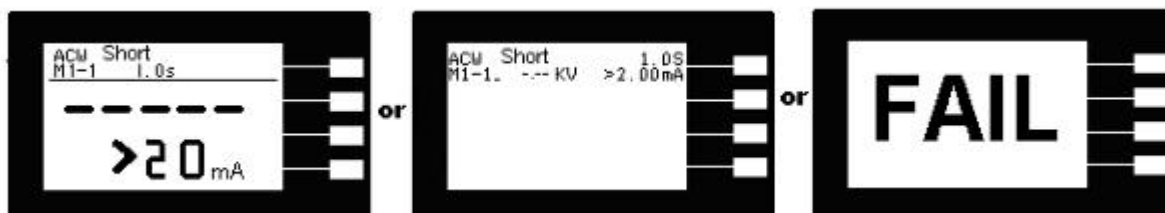

withstand voltage Breakdown(Breakdown)

During AC voltage withstand test If the leakage current of the measured object is far beyond the range that can be measured by this analyzer, and the current of the arc is far beyond the positive constant value which can be measured by this analyzer, the program will be judged as the failure of the test caused by voltage collapse.LCD the LCD display displays ACW Breakdown,As shown in the picture



Leakage current lower limit(Min Lmt)

During AC voltage withstand test If the leakage current of the object under test is less than the lower limit setting value, the program will judge the test failure caused by the lower limit of leakage current.LCD the LCD display displays Min-Fail,As shown in the picture



Failure of arc test (Arc Fail)

During AC voltage withstand test If the leakage current of the object under test is within the upper limit of the set leakage current, but the current of the arc exceeds the set value of the arc current, the test failure will be judged as the test failure caused by the arc of the object under test.LCD the LCD display displays Arc Fail,As shown in the picture



Test pass (Pass)

If the object under test passes the test without any abnormal phenomena during the whole process of the AC withstand voltage test,Was identified as passing the test.LCD the LCD display displays Pass,As shown in the picture

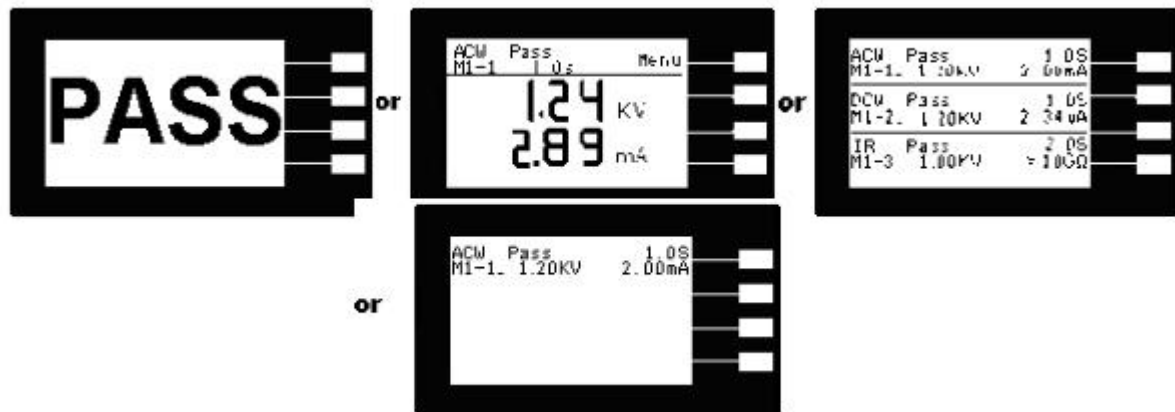

4.3.1.2 DC withstand voltage test:

Test abort (Abort)

If the DC withstand voltage test is in progress and the test is interrupted by RESET switch or remote control device, the LCD display displays DCW Abort,As shown in the picture



Ramp Up test (Ramp Up)

If the DC withstand voltage test is set to a Ramp Up (Ramp Up) test program, before the analyzer reads the first test result,LCD the LCD display displays DCW Ramp Up,As

shown in the picture

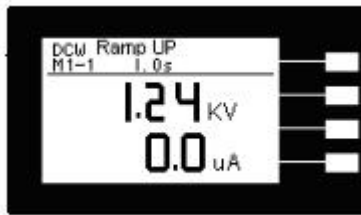

Ramp down test (Ramp DN)

If the DC withstand voltage test is set to a Ramp down(Ramp DN) test program, before the analyzer reads the first test result,LCD the LCD display displays DCW Ramp DN,As shown in the picture

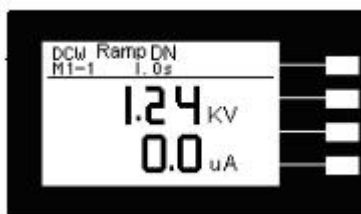

Test time (Dwell)

When DC withstand voltage test is carried out, the test results are constantly updated. Before the analyzer reads the first test result, LCD the LCD display display DCDwell, as shown below

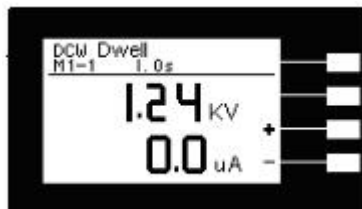

The upper limit of leakage current (Max Lmt)

If the leakage current of the tested object exceeds the set value of the upper limit during DC withstand voltage test, the program will judge the test failure caused by the upper limit of leakage current.,LCD the LCD display displays Max-Fail,As shown in the picture

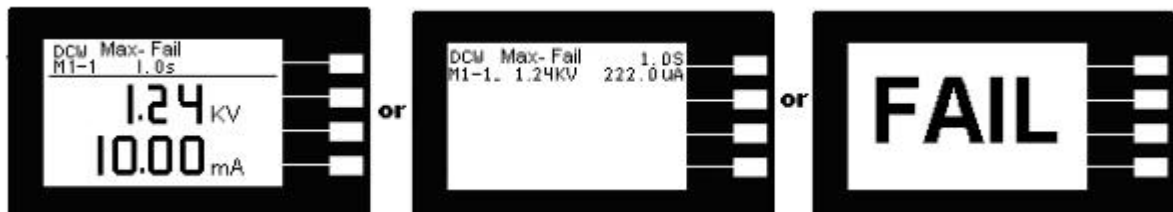

Short (Short)

During AC voltage withstand test If the leakage current of the tested object is far beyond the range that can be measured by this analyzer when it is tested for DC withstand

voltage, and the special action of short circuit judgment circuit of this analyzer, the program will judge the test failure caused by short circuit. LCD the LCD display displays DCW Short, As shown in the picture



withstand voltage Breakdown(Breakdown)

During AC voltage withstand test If the leakage current of the tested object in the DC withstand voltage test is far beyond the range that can be measured by this analyzer, and the current of the arc is far beyond the normal value which can be measured by this analyzer, the program will be judged as the test failure caused by the withstand voltage collapse. LCD the LCD display displays DCW Breakdown, As shown in the picture

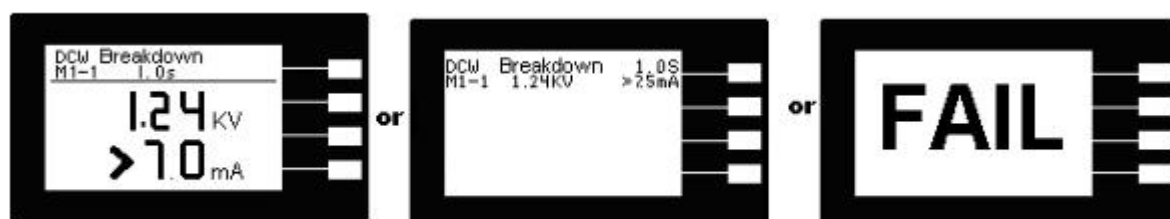

Leakage current lower limit (Min Lmt)

During AC voltage withstand test If the leakage current of the object under test is lower than the lower limit setting value, the program will judge the test failure caused by the lower limit of leakage current. LCD the LCD display displays Min-Fail, As shown in the picture



Failure of arc test(Arc Fail)

During AC voltage withstand test If the leakage current of the object under test is within the upper limit of the set leakage current, but the current of the arc exceeds the set value of the arc current, the test failure will be judged as the test failure caused by the arc of the object under test. LCD the LCD display displays Arc Fail, As shown in the picture

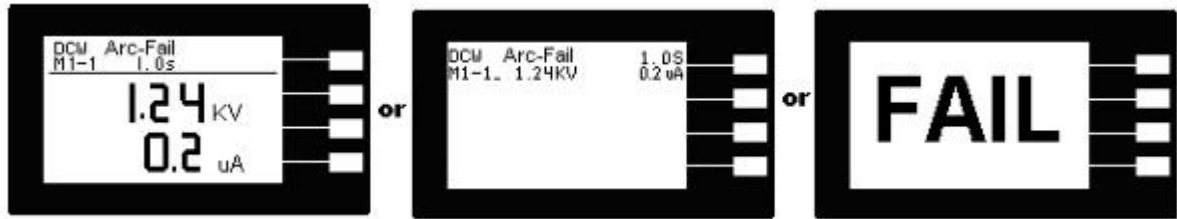

Test pass (Pass)

If the object under test passes the test without any abnormal phenomena during the whole process of DC withstand voltage test, Was identified as passing the test. LCD the LCD display displays DCW Pass, As shown in the picture

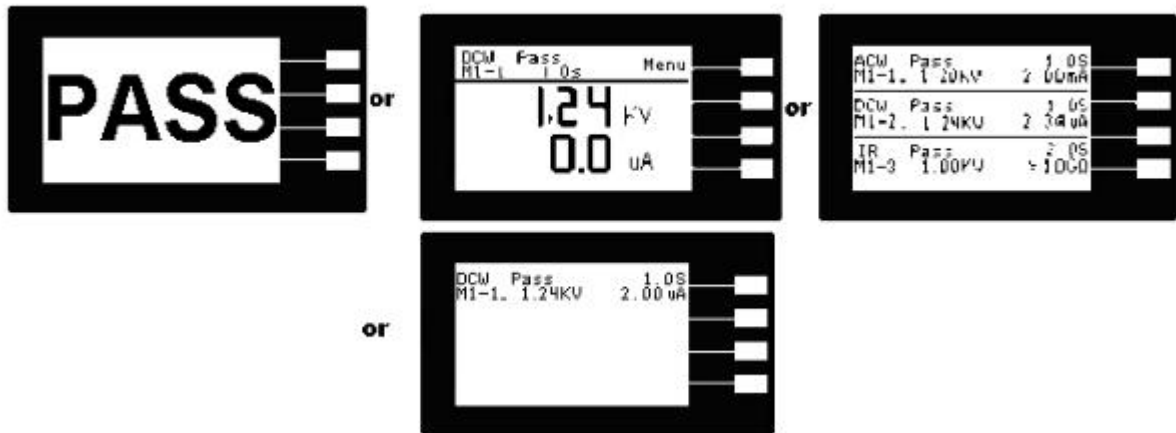

4.3.3 Insulation impedance test

Test abort (Abort)

If the insulation impedance test is in progress, and when the RESET switch or remote control device is used to interrupt the test, LCD the LCD display displays IR Abort, As shown in the picture

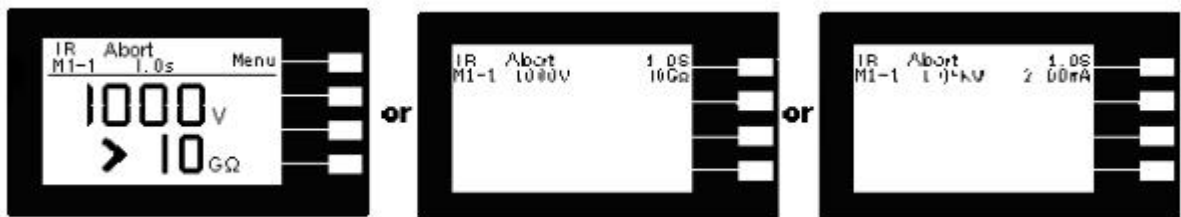

Rame up test (Ramp Up)

If the insulation impedance test is set to a Ramp Up test program, before the analyzer reads the first test result, LCD the LCD display displays IR Ramp Up, As shown in the picture

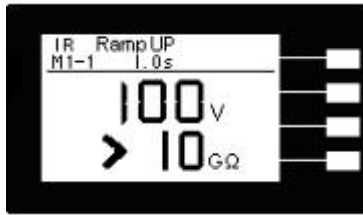

Ramp down test (Ramp DN)

If the insulation impedance test is set to a Ramp DN test program, before the analyzer reads the first test result, LCD the LCD display displays IR Ramp DN,As shown in the picture

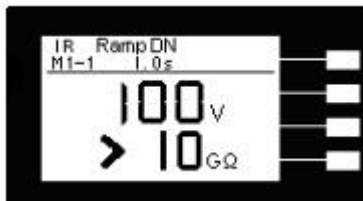

Delay time (Delay)

At the beginning of the insulation impedance test, during the period during which the test voltage is gradually increasing, the analyzer has not yet read the first test result.LCD the LCD display displays IR Delay,As shown in the picture



Upper limit of insulation impedance (Max Lmt)

When the insulation impedance is tested If the impedance value of the object under test exceeds the set value of the upper limit, it will be judged as the test failure caused by the upper limit of the insulation impedance by the program.LCD the LCD display displays Max-Fail,As shown in the picture

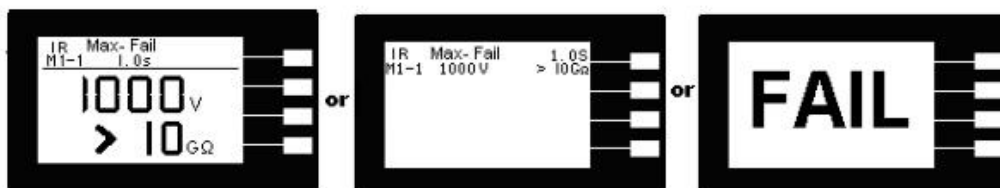

Insulation impedance lower limit (Min Lmt)

When the insulation impedance is testedIf the impedance value of the object under test is lower than the setting value of the lower limit, the program will judge the test failure caused by the lower limit of the insulation impedance, and the LCD display will display Min-Fail,As shown in the picture

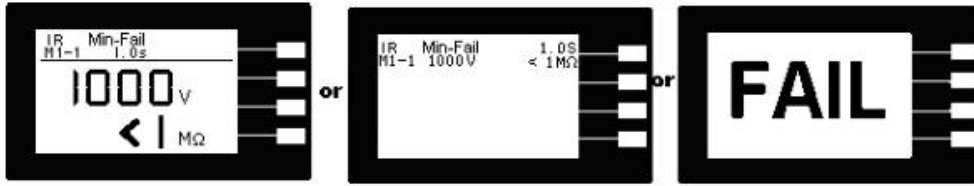

Test pass (Pass)

If there is no abnormality in the whole process of testing the insulation impedance of the object under test, it is considered to pass the test and the LCD will display IR PASS,As shown in the picture

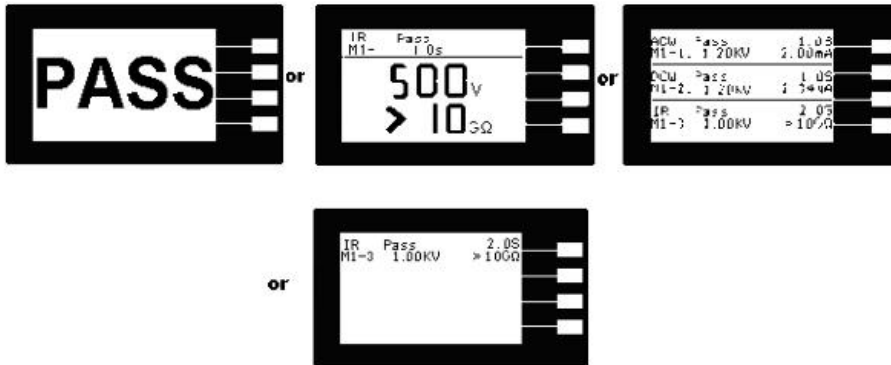

4.4 Validation of test function

When the boot screen shows the product model, press the "TEST" button, you can enter the test function to confirm the status of self-test, to determine whether the various functions of the withstand voltage test is normal, The RESET switch and the EXIT key can act as an operation key to leave the self-test in progress.As shown in the picture

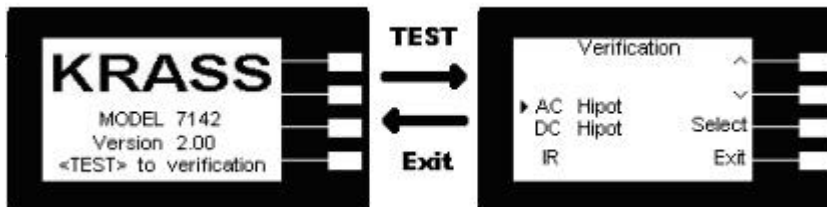

1. AC Hipot Self detection function: with " ~ " " ^ "KEY,select"AC Hipot",then press "Select"KEY,Then output HV and RETURN terminal test line short circuit,press "TEST" KEY,At this point, the HV and RETURN terminals will output a voltage of about 1KVAC. The detection is successful, and LCD shows Verification OK AC Hipot failure detected,Detection failure,LCD display AC Hipot failure not detected .Check leads or call KrassAs shown in the picture

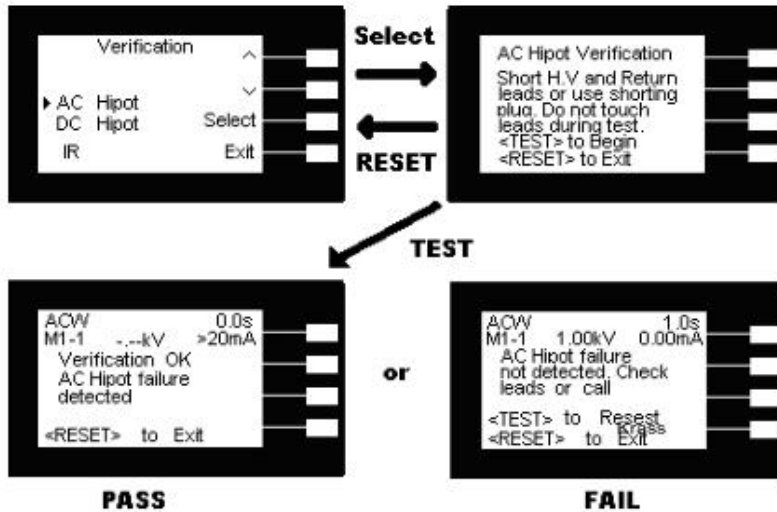

2. DC Hipot Self detection function: with " ~ " " ^ " KEY,select "DC Hipot ",then press "Select" KEY,then output HV and RETURN terminal test line short circuit,press"TEST"KEY,at this point ,HV and RETURN terminals will output a voltage of about 1KVDC,Test success,LCD display Verification OK DC Hipot failure detected,Detection failure,LCD display DC Hipot failure not detected .Check leads or call Krass ,As shown in the picture

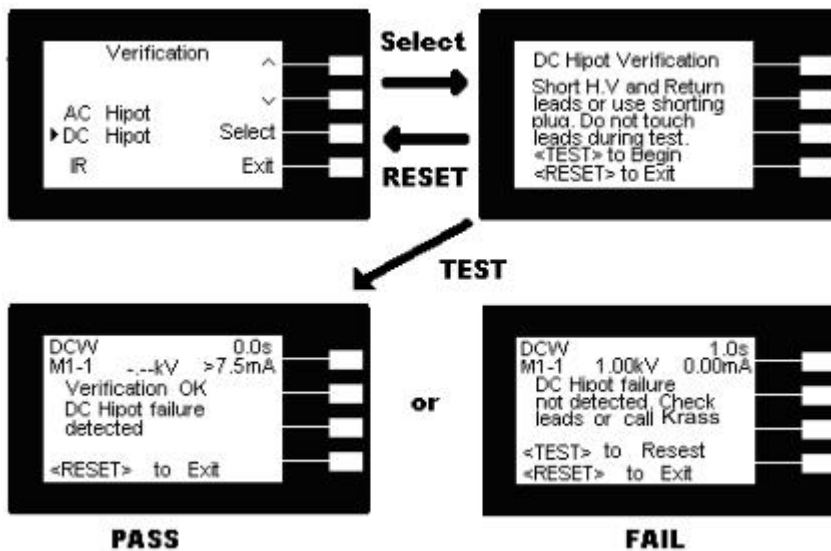

Krass

3. IR Self detection function:with " ~ " " ^ " KEY,select"IR",then press "Select" KEY,then output HV and RETURN terminal test line short circuit,press"TEST" KEY,at this point ,HV and RETURN terminals will output a voltage of about 1KVDC,Test success,LCD display Verification OK IR failure detected,Detection failure,LCD display IR failure not detected .Check leads or call Krass Krass.

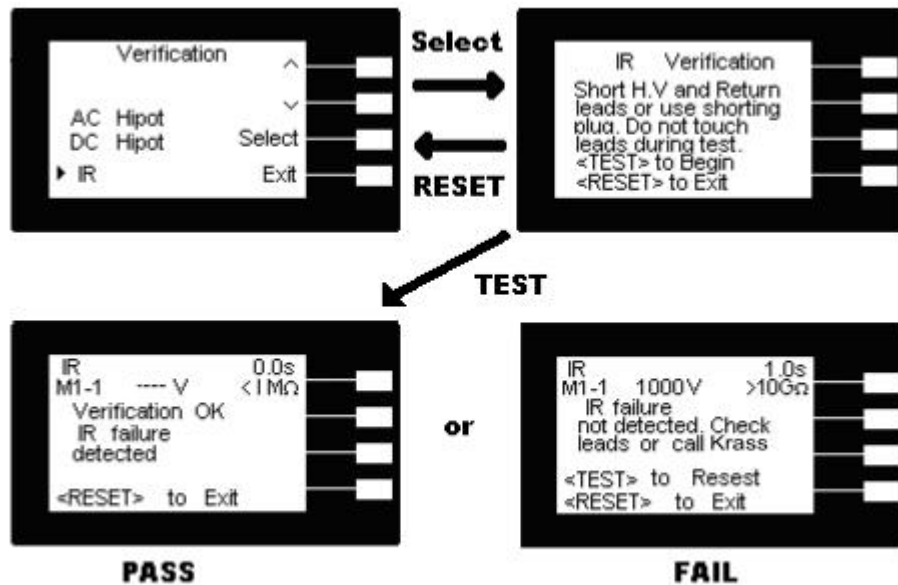

4.5 Operation procedures and procedures

7100 series pressure tester is mainly designed for production line automation and quality analysis and inspection. Its operation and setting are very simple. Unreasonable setting and operation will give two short beep warning and return to the original set state. Please operate the analyzer according to the following procedures and procedures.

1. Before connecting the plug of the input power line of the analyzer to the market power supply, please turn off the input power switch of the analyzer, and switch the voltage selector switch on the back board to the correct input voltage position, and check whether the fuse specifications are correct. Then the ground wire is connected to the grounding terminal on the backplane of the analyzer.
2. Please connect the input power cord to the analyzer and the power socket respectively, but do not connect the test line to the output terminal of the analyzer first.
3. Firstly, all the test lines of the test object or its test fixture are connected, and then the loop (Return) is connected to the loop terminal of the analyzer. The test wire of the ground wire of the object under test is connected to the terminal of the analyzer. Finally, the high-voltage test wire is connected to the high-voltage terminal of the analyzer and all the test wires are checked to see if they are all connected properly.
4. Then the input power switch of the analyzer is turned on, and the program will automatically display the memory group and test parameter data of the last test of the analyzer, and enter the mode of waiting for test and parameter setting.

Note: If the memory group MX-X is followed by "_", it means that the step is automatically connected to the next test step after the test is completed.

5. Please refer to the general test parameter setting instructions, the general test parameters of this analyzer, PLC Remote (PLC Remote), Single step link test (Single Step), Alarm volume (Alarm), LCD contrast brightness (Contrast), Test result selection (Results), Keyboard lockout (Lock), Program memory group locking (Mem Lock), The grounding interrupt stop (Smart GFI) Set finish.

6. If you want to reset the test parameters, press Test key to set the parameters mode,

reset the test parameters, detailed settings, procedures and steps, please refer to the test parameters setting instructions. If the keyboard is locked, please refer to the instructions for keyboard locking, unlock the keyboard before setting the test parameters.

7. If you want to select the test parameters in the memory group for testing, press Menu key. The program will enter the selection mode of the memory group. Use Memory key to select the program memory group to be tested. When the memory group is selected, press Exit key to leave. The program will automatically call out the test parameters of the memory group and return to wait for testing and Set the pattern.

8. If you want to re-select the parameters of the test steps in the memory group for testing, press the STEP key, and the program will enter the selection mode of the memory group step. The test step is 1~3 with 3 steps. If you want to connect the test step to the next step for connection testing, refer to the "Test Parameter Settings" instructions and select Connect as ON.

9. If you want to test, please press the TEST switch, at this time the red high voltage symbols on the panel will flicker, do not touch the object under test during the test, in order to ensure safety.

10. If you want to stop the test during the test, press RESET switch, this analyzer immediately stop the test, LCD display will retain the test value at that time. If you want to continue the test, press the TEST switch on the panel again. The program will continue to test the incomplete test steps. If you want to start the test again from the first test step, press the RESET switch and then the TEST switch. The program will automatically start the test from the first test step.

11. If the test fails, the analyzer immediately stops testing and the display displays the status and value of the failure, at which point the indicator in the red REST switch will be on and a beep warning sound will be issued. If you want to continue testing, press the TEST switch on the panel again, and the program will continue testing the incomplete testing steps. If you want to start the test again from the first test step, press RESET switch, then TEST switch, the program will automatically start the test from the first test step. You can also press the RESET switch to turn off the alarm sound and retain the test read value, but when you press the TEST switch again, the program will automatically start testing from the first test step. For all kinds of display information that failed in the test, please refer to the instructions for display information.

12. If you want to use an external remote control to operate this voltage tester, connect the remote control to the remote control input terminal on the backplane. The functions and functions of the TEST and RESET switches on the remote controller are exactly the same as those on the analyzer.

13. The analyzer has PASS, FAIL and PROCESSING The output of remote monitoring signals and the function of remote calling three memory groups, if you want to use these functions, please refer to the description of remote input and output signals.

14. 7130, 7132, 7140 and 7142 can be connected to the AC grounding impedance tester 7315 of our company. Connection testing is divided into two ways, one is to test at the same time, the other is After the grounding impedance test or voltage withstand test is completed, another function test will be carried out.

4.6 Withstand voltage / insulation tester and Ground impedance tester continuous test

The withstand voltage/insulation tester (7130/7132/7140/7142) can be connected with the AC grounding impedance tester (7314/7315/7316). It can be tested in two ways:

1. The AC grounding impedance test is performed first, and then the withstand voltage test is performed after the AC grounding impedance test is completed and passed.
 2. AC grounding impedance test and withstand voltage test are executed simultaneously.
- Most of the safety codes and regulations enforcement units require the first test method. The second way is mostly for the manufacturer to execute the two tests simultaneously in order to shorten the manufacturing hours. In theory, the simultaneous execution of the two tests will not cause any problems or dangers, but if one of the instruments is in abnormal condition. Occurs, is very likely to cause danger or injury to the operator, may also cause another instrument to follow abnormal conditions.

Wiring and description of AC voltage withstand test for AC grounding impedance test

1. The connection mode is controlled by the AC grounding impedance test as the host (Msater). After the AC grounding impedance test is completed and passed, the withstand voltage test is executed or the connection mode is output at the same time as shown in Figure (A).

2. When 7314/7316 is connected with KRASS withstand voltage tester, the output Return line of withstand voltage tester and the AC grounding impedance test line are directly connected to the DUT. The 7314/7316 machine itself has no common ground terminal connected with the output of withstand voltage tester.

Notes : 1217 The connecting line of grey signal connects one end to 7142 Signal Output and the other end to 7314/7315/7316 Signal Input

Input 1218 The connecting line of white signal connects one end to 7142 Signal Input and the other end to 7314/7315/7316

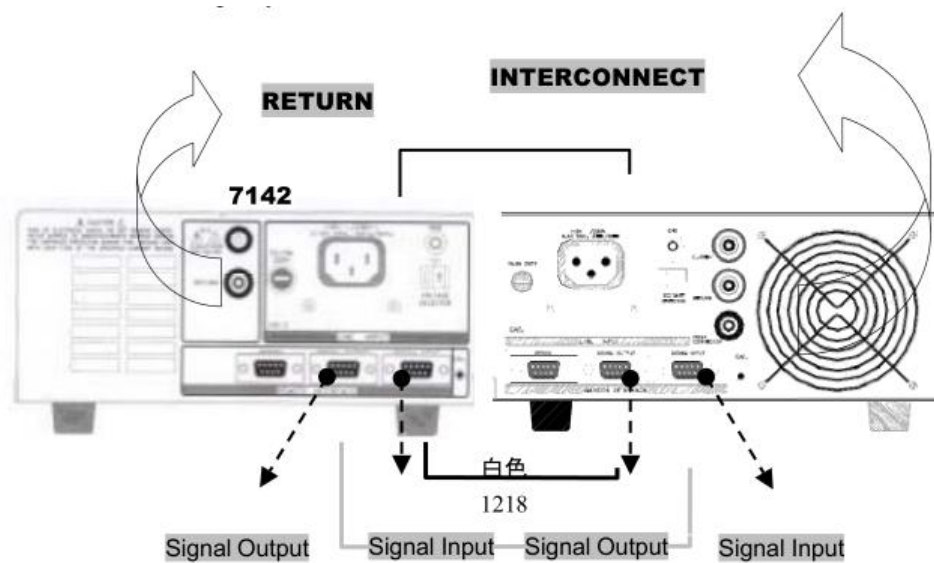

圖(A)

灰色 1217

Chapter five Interface description

5.1 Standard remote control interface (Remote I / O)

The back panel of the analyzer is equipped with two D-type (9PIN) connection terminals to provide remote control input control signals and output information output. These connection terminals and standard D type (9PIN) connectors match each other and must be provided by users themselves. In order to achieve the best results, it is recommended to use the isolation line as the control or information connection line. In order not to make the isolation ground wire become a loop and affect the isolation effect, the isolation grid at one end of the isolation line must be grounded.

Backplane remote control interface

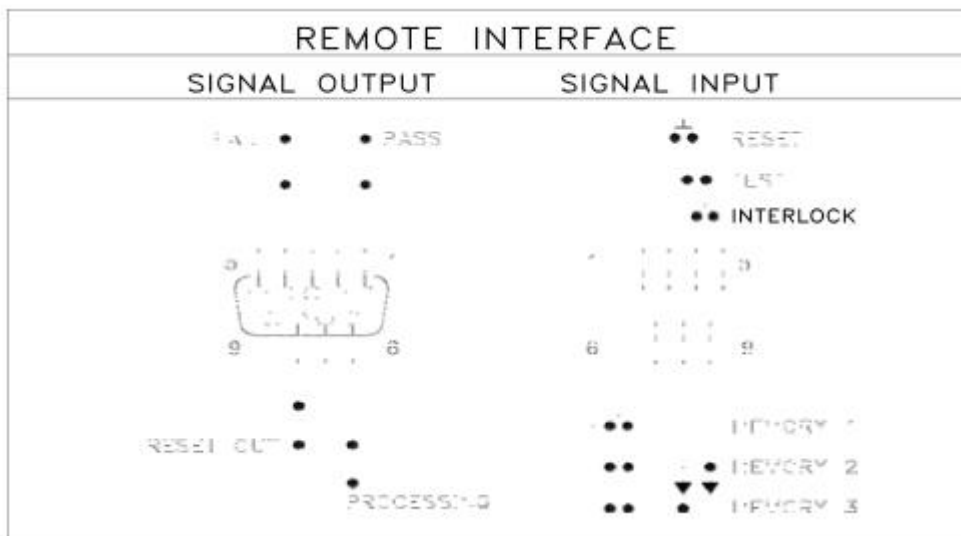

5.1.1 Remote control signal output (Signal Output)

A remote control signal output terminal is provided on the back board of the analyzer, which can provide remote control monitoring for the test passing (PASS), test failure (FAIL), test stop/reset (REST) and test in (PROCESSING). The status quo of these signals is provided by three relays (Relay) inside the instrument, Normally open (N.O.) contacts without power supply. The capacity of its contacts is: : AC 250V 1.0 Amp / DC 250V 0.5 Amp.

Note: These contacts have no positive or negative polarity restrictions, and each signal is a separate wiring without a common ground line (COMMON). The signal is output from the D (9 PIN) connection terminal configured on the back of the analyzer. The terminal is marked with the foot number. The wiring of each output signal is as follows:

1. PASS signal connected between PIN 1 and PIN 2.
2. FAIL signal connected between PIN 3 and PIN 4.
3. PROCESSING signal connected between PIN 5 and PIN 6.
4. REST OUT signal connected between PIN 7 and PIN 8.
5. empty pin Connect to PIN 9 for unused empty feet.

5.1.2 External control signal input and memory program(Signal Input)

The back panel of this analyzer is equipped with remote control signal input terminals, which can be operated by external remote control devices. The functions or calls of INTERLOCK, TEST and RESET of the instrument can be preset on any set of test parameters in the three memory programs, and the test can be carried out directly by using another test switch without the panel setting and use. The "TEST" switch on the panel. When the PLC remote control function is set to ON, the TEST switch on the panel is set to be inoperable to avoid misoperation and danger caused by double operation. The RESET switch on the panel can still be operated so that the high voltage output can be turned off anytime and anywhere.

Note: If you do not use the remote control device to operate, you need to unlock the attachment (INTERLOCK) and install it on the remote control signal input terminal.

The following is the connection mode of remote control device:

1. RESET control The control switch is connected between PIN 2 and PIN 5.
 2. TEST control The control switch is connected between PIN 3 and PIN 5.
 3. INTERLOCK control The control switch is connected between PIN 4 and PIN 5.
- PIN5 is the common (COMMON) ground wire for remote control circuits.

Note: Never connect any other voltage or current power, if input other power, will cause damage to the instrument internal control circuit or misoperation.

Remote memory program input, The normally open (N.O.) transient (MOMENTARY) switch must be used as a control tool.

the connection mode is as follows:

1. The first set of memory programs The control switch is connected between PIN 7 and PIN 8.
 2. The second sets of memory programs The control switch is connected between PIN 7 and PIN 9.
 3. The third sets of memory programs The control switch is connected between PIN 7 and PIN 8 and PIN9.
- PIN 7 is the common (COMMON) ground wire for remote memory program input circuit.

Indicate:

1. PIN 1, PIN 4 and PIN 6 are unused empty feet.
2. Remote control input signals are divided into two groups: remote control operation and remote memory program group. The power supply and common ground wire of each group are independent and can not be confused.

5.1.3 Remote Signal sequence diagram

1. The shortest test time is 0.4S, Ramp Time (0.1S) + Dwell Time (0.3S)
2. PASS LED Signal synchronization with PASS signal
3. FAIL LED Signal synchronization with FAIL signal

4. ALARM Signal same PASS or FAIL

ACW

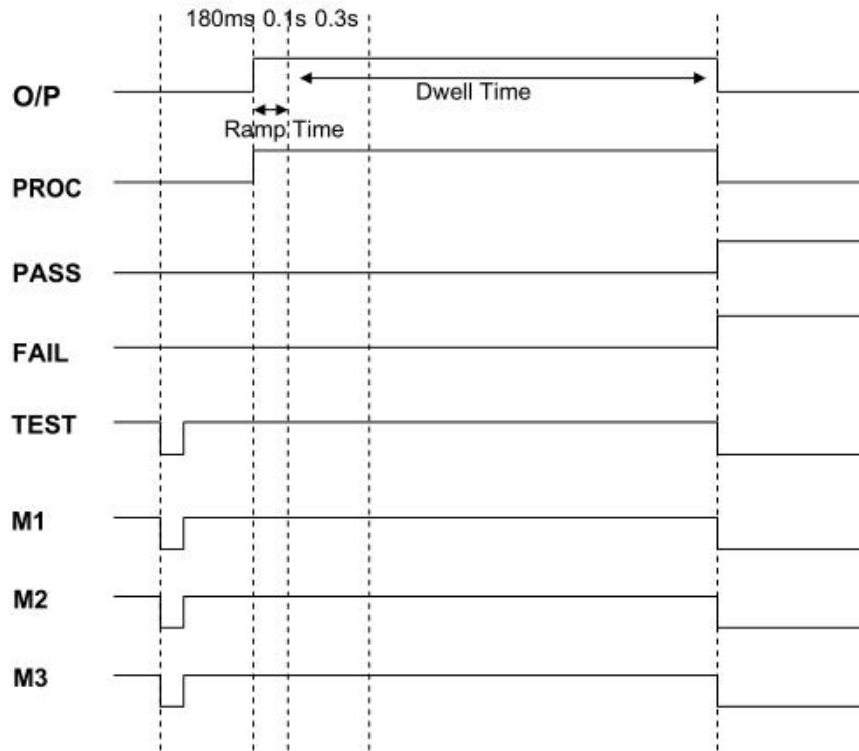

DCW

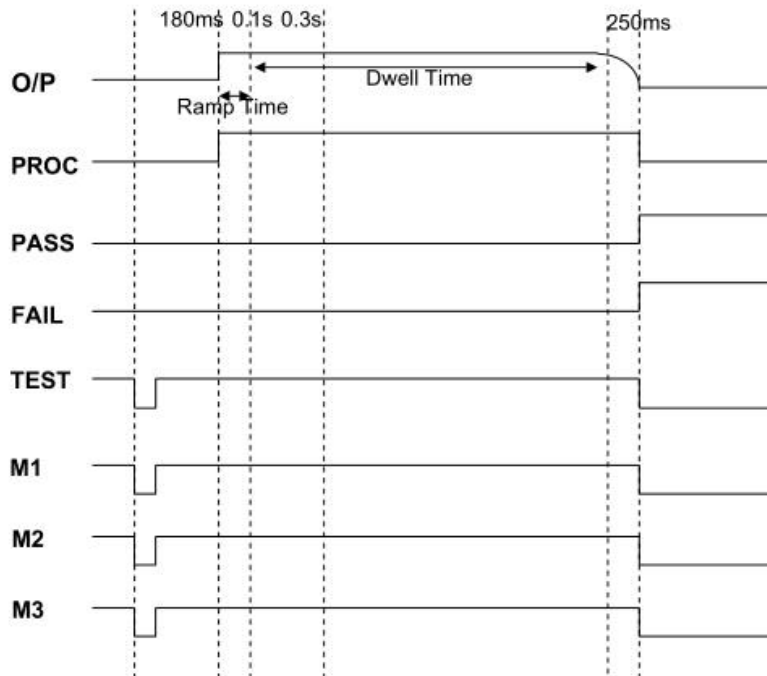

特殊 DCW

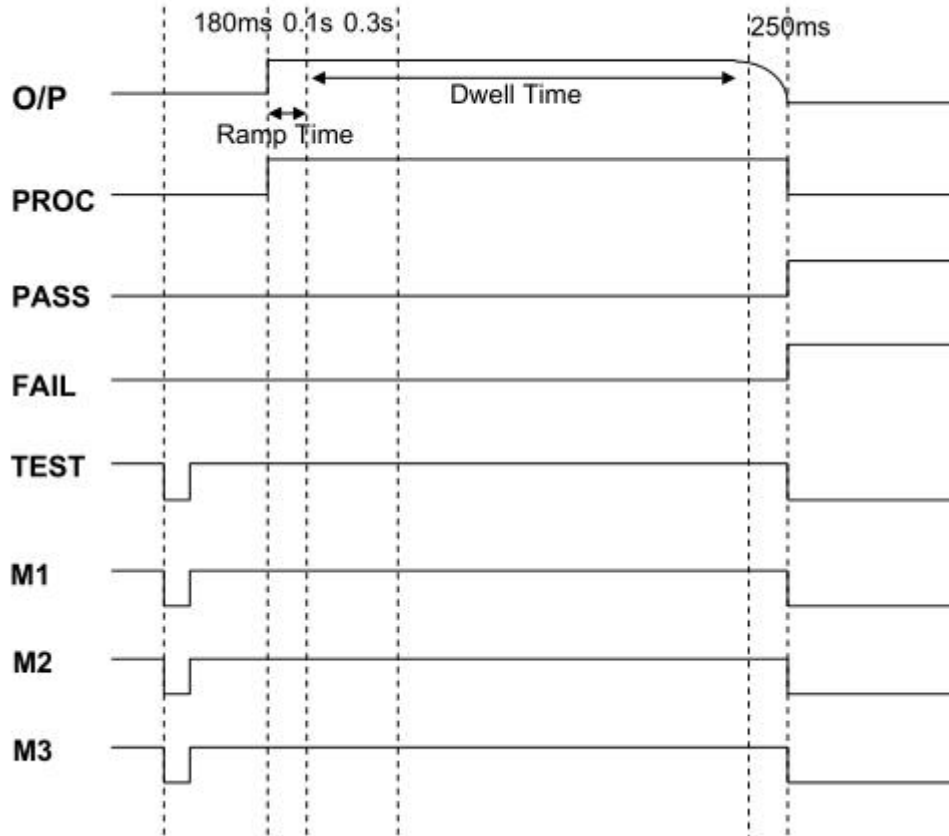

5.2 RS485 Interface (optional)

A D type (9PIN) connection terminal is arranged on the backplane of the analyzer. It provides connection for RS485 interface card. This connection terminal is used to connect to the RS485 interface card with the standard D (9PIN) connection line must match each other, up to 100 simultaneous connection tests. (Please ensure that the connection is shown in the following illustration.)

5.2.1 Wiring method

5.2.1 接線方法

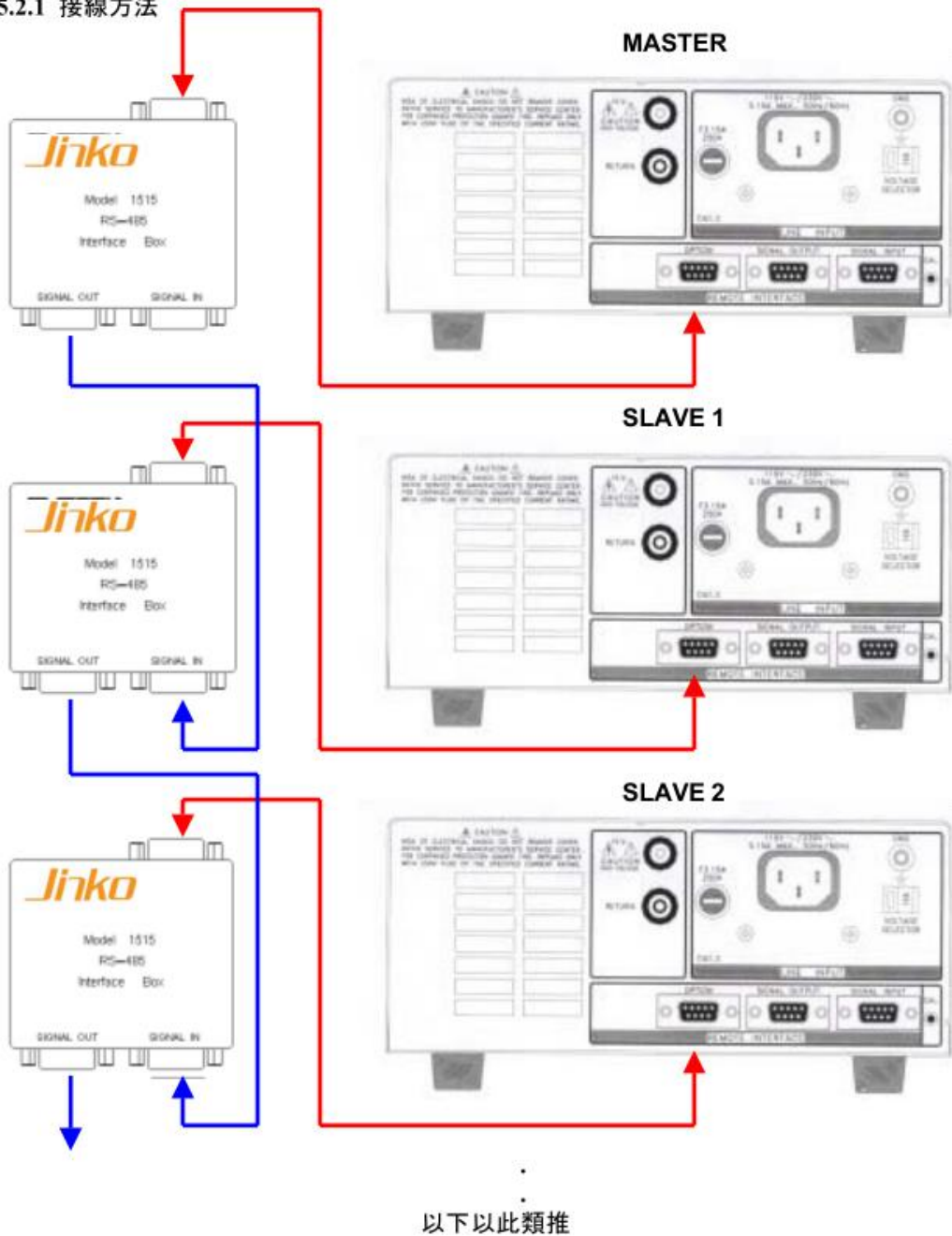

Parameter setting

Master setting :Choose "Master" or "Slave" in the "485 Mode" with "+" key in "SYSTEM".After selecting Master, use the "^" or "v" button of the panel to move to the number of SlaveQty settings.Master need to be deducted.As shown in the picture



Slave setting: Choose "Master" or "Slave" in the "485 Mode" with "+" key in "SYSTEM". After selecting Slave, move the "^" or "v" button on the panel to Address to set the location of each table. The number must start from 1, and it must be continuous and not repeatable. As shown in the picture

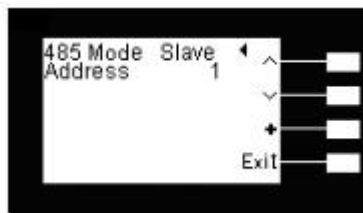

5.2.2 List of instructions

The following instructions are used to drive the ON/OFF function or to select various parameter tables. When executing these instructions, you do not need to use any other numeric or parameter.

COMMANDS & QUERY DISCRPTION

SETTING COMMAND	COMMAND
ADDRESS(X)	X nnn
TEST	TEST
RESET	RESET
MEMORY:STEP:SELECT:mn	MSS mn
ACW	ACW
DCW	DCW
IR	IR
VOLTAGE:XXXX	VOLT nnnn
MAX_LIMIT:XXXX	MAXL nnnn
MIN_LIMIT:XXXX	MINL nnnn
RAMP_UP:XXXX	RUP nnnn
DWELL_DELAY_TIME:XXXX	DDT nnnn
RAMP_DOWN:XXXX	RDN nnnn
ARC:X	ARC n
FREQUENCY:XX	FREQ nn
CONTINUITY:X(ON=1,OFF=0)	CONT n
CONTINUITY:MAX_LIMIT:XXX	CMAL nnn
CONTINUITY:MIN_LIMIT:XXX	CMIL nnn
CONTINUITY:OFFSET:XX	COFF nn
CONTINUITY:AUTO_OFFSET	CAOF
AUTO_OFFSET	AOFF
AUTO_CHARGE	ACHA
CHARGE_LOW	CHAR nnnn
CONNECT:X(ON=1,OFF=0)	CONN n
PLC_REMOTE:X(ON=1,OFF=0)	PLC n

SINGLE_STEP:X(ON=1,OFF=0)	SSTP n
ALARM:X	ALAR n
CONTRAST:X	CNTR n
RESULTS:X(Last=L,All=A,P/F=P)	RLT n
SMART_GFI:X(ON=1,OFF=0)	SGFI n
POLL:XXX	POLL nn
P:XXX	P nn
STEP_ALL:(ALL PARAMETER)	SALL nn,nn
TEST_DATA_QUERY:?	TD?
RESULT_DATA_QUERY:n?(n=STEP)	RD n?
STEP_ALL_QUERY:?	SALL?
READ_RESET_QUERY:?	RR?
READ_INTERLOCK_QUERY:?	RI?

COMMANDS & QUERY SEND_OUT

COMMAND DISCRIPTION	COMMAND
TEST	TEST
RESET	RESET
MEMORY:STEP:SELECT:mn	MSS mn
POLL:XXX	POLL nn
STEP_ALL:(ALL PARAMETER)	SALL nn,nn...
TD?	MX-X_,FUNC,STATUS,V,A(R),T
RD n?	MX-X_,FUNC,STATUS,V,A(R),T
SALL?	SALL nn,nn...
RR?	n (0=CLOSE,1=OPEN)
RI?	n (0=CLOSE,1=OPEN)

Chapter six Instrument correction

The instrument has been calibrated according to the national standard calibration procedure before leaving the factory. The accuracy of the instrument fully conforms to the specifications on the electronic catalogue of JIN AI LIAN, even more precise. The manual also contains a "calibration statement" which suggests that the instrument should be calibrated at least once a year, and the calibration standard instrument should be used for calibration. Accuracy must be within 0.5% to ensure that the accuracy of the instrument fully conforms to the specifications on the electronic catalogue.

6.1 Correction step

Press the backplane "CAL" KEY to boot and enter the correction mode (as shown below).

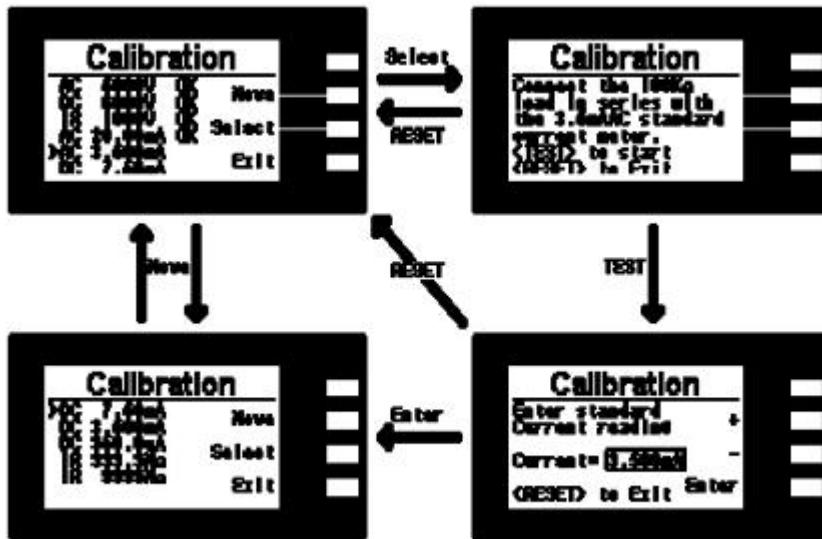

ACW Voltage correction

With "Move" KEY, select "AC 5000V", and then press "Select" KEY, A standard high voltage voltmeter is connected to the output HV and RETURN terminals in parallel. According to TEST KEY, the HV and RETURN terminals will output a voltage of about 5KVAC, input the standard high voltage voltmeter reading value, and then press ENTER KEY.

DCW Voltage correction

With "Move" KEY, select "DC 6000V", and then press "Select" KEY, A standard high voltage voltmeter is connected to the output HV and RETURN terminals in parallel. According to "TEST" KEY, a voltage about 6KVDC will be output at this time. The standard voltmeter reading value will be input, and then press "ENTER" KEY.

IR Voltage correction

With "Move" KEY, select "IR 1000V", and then press "Select" KEY, A standard high voltage voltmeter is connected to the output HV and RETURN terminals in parallel. According to "TEST" KEY, a voltage of about 1KVDC will be output at this time. The standard voltmeter reading value will be input, and then press "ENTER" KEY.

ACW High current correction

With "Move" KEY, select "AC 20.00mA", and then press "Select" KEY, in the output HV, RETURN terminal connected with a load of about 100KΩ, Then a standard ammeter is connected in series, according to "TEST" KEY, at this time about 1 KVAC voltage will be output, the standard ammeter reading value input, and then press "ENTER" KEY can be.

ACW Low current correction

With "Move" KEY, select "DC 3.500mA", and then press "Select" KEY, in the output HV, RETURN terminal connected with a load of about 100KΩ, and then in series with a

standard ammeter, according to "TEST" KEY, at this time will output about 300 VDC voltage, the standard ammeter read value input, and then press "ENTER" KEY can be.

DCW high current correction

With "Move" KEY,select "DC 7.50mA", and then press "Select" KEY,in the output HV,RETURN terminal connected with a load of about 100K Ω ,and then in series with a standard ammeter, according to "TEST" KEY, at this time will output about 700 VDC voltage, the standard ammeter read value input, and then press "ENTER" KEY can be.

DCW Low current correction

With "Move" KEY,select "DC 3.500mA", and then press "Select" KEY,in the output HV,RETURN terminal connected with a load of about100K Ω ,and then in series with a standard ammeter, according to "TEST" KEY, at this time will output about 300 VDC voltage, the standard ammeter read value input, and then press "ENTER" KEY can be.

DCW Low current correction

With "Move" KEY, select "DC 350.0 μ A", and then press "Select" KEY, in the output HV, RETURN terminal connected with a load of about 1M Ω , and then in series with a standard ammeter, according to "TEST" KEY, at this time will output about 300 VDC voltage, the standard ammeter read value input, and then press "ENTER" KEY can be.

IR Low resistance correction

With "Move" KEY, select "IR 999.9M", then press "Select" KEY, in the output HV, RETURN terminal connected with a standard resistance 50M Ω , press "TEST" KEY, at this time will automatically read the standard resistance input, that is, complete Low resistance correction.

IR High resistance correction

With "Move" KEY, select "IR 9999M", then press "Select" KEY, in the output HV, RETURN terminal connected with a standard resistance 50M Ω , press "TEST" KEY, at this time will automatically read the standard resistance input, that is, complete high resistance correction.

6.2 Correction completion

After input correction parameters, the instrument must first turn off the input power and then switch on.otherwise it can not enter the mode to be measured. When the input power is switched off, the program automatically stores the correction parameters in the corrected memory body. The program does not accept unreasonable input, if there is unreasonable input will issue a Two-life short "beep" warning and return to the original state, waiting for re-input.

Please pay special attention to the following matters.

- The EXIT key and the RESET switch can act as an operation key to leave the correction mode in progress.

- After calibration, the instrument must first turn off the input power and then turn on, otherwise the instrument can not enter the set or to be measured mode.
- The correction parameters stored will be stored in the memory body, and will not change or disappear unless changed again.
- It is suggested that the calibration period of this pressure tester is one year.