

---

---

# Operating Instruction

**JK-XU/XA/XC TYPE**

Model JK-XU/XA

## Multi-channel Temperature Tester

Vear1.0

---

Address: C3, Building 23 of New-power Entrepreneurship Centre, No1, QingYang North Road, Tianning District,  
Changzhou City, Jiangsu Province

Tel:0519-85563477 85565067 853969285

Fal:0519-85565067

Website:Http:[www.jaldz.com](http://www.jaldz.com)

Email:[mailjk17@126.com](mailto:mailjk17@126.com)

Statement of Company:

What this instruction describes may not be all content of the instrument, Jin Ai Lian Company has the right to improve and enhance the products' performance, function, internal structure, appearance, accessories, packaging and so on without prior instructions! If it caused any inconsistency between the specification and instrument, please contact our company.

## Packing List

The user should check the packing list carefully after purchase, if there is any inconsistency, please contact the customer; The packing list is as follows

- |   |                   |
|---|-------------------|
| 1. JK-XU multi-channel temperature patrol-check device host | 1 piece           |
| 2. Model ____ thermocouple                                  | ____ set×8 pieces |
| 3. Power line   | 1 piece           |
| 4. RS232 communication cable                                | 1 piece           |
| 5. Supporting software disk                                 | 1 piece           |
| 6. Product manual   | 1 piece           |
| 7. Inspection certificate                                   | 1 piece           |
| 8. Warranty card  | 1 piece           |

### Chapter One Fundamental Principle

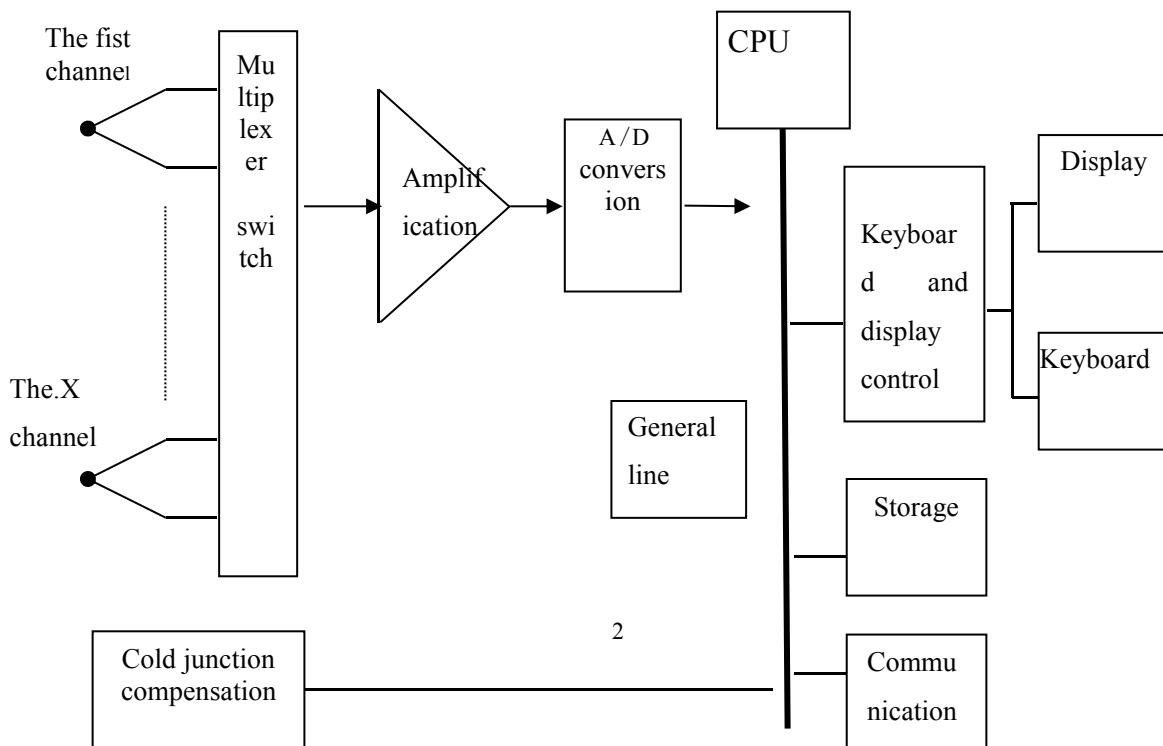

The first channel	The X channel
Multiplexer switch	Amplification
A/D conversion	General line
Cold junction compensation	Keyboard and display control
Display	Keyboard
Storage	Communication

## Principle Diagram

As the above principle diagram shows: when multi-channel temperature patrol-check device passes the multi-channel temperature sensor (thermocouple) it will be converted into voltage for output by the difference in temperature of the measuring point and working end, a way is chosen through the multiplexer switch, and then it will be converted to digital signals for micro processor through A/D after amplification. Cold junction compensation probe monitors the environment temperature. Microprocessor calculates the temperature value by checking the thermocouple indexing table according to the electromotive force that the thermocouple outputs and the temperature that the cold junction compensation probe outputs.

## Chapter Two Technical Index

### 3.1 Main technical index

- 1.Measurement range of temperature:  $-100^{\circ}\text{C} \sim 1000^{\circ}\text{C}$ ; (Standard sensor temperature range:  $-50-300^{\circ}\text{C}$  )
- 2.Measurement accuracy:  $0 \sim 1000^{\circ}\text{C} : \pm (\text{Numerical value} \times 0.5\% + 1)^{\circ}\text{C}$ ,  
 $-100 \sim 0^{\circ}\text{C} : \pm (\text{Numerical value} \times 0.5\% + 2)^{\circ}\text{C}$ ;
- 3.It has anti-high frequency interference function.
4. Number of input channel for temperature signals: 8 sets can be configured at most, with 8 ways per set; (according to the model)
- 5.Sensor: Nickel chromium - Nickel silicon ( model K) thermocouple (model T, model J can be made specially).

(About the measurement: 1: We suggest measuring without the thermocouple as each thermocouple has a tiny difference, 2: Only the first channel needs to be measured for each 8 ways, because each set of thermocouple is measured via the first channel. We suggest measuring in the space of about  $\underline{23}^{\circ}\text{C}$ )

### 3.2 Allowed environment condition

- 1.Power supply: AC  $220\text{V} \pm 10\%$ ,  $50\text{Hz} \pm 2\%$ ;
- 2.Using environment: operating temperature:  $-20 - 70^{\circ}\text{C}$ , relative humidity:  $20\% - 90\%$ ;

3. The maximum potential difference between thermocouples: <350V (the true effective value)

### 3.3 Volume

1. Overall dimension: (length × width × height) 30cm×25cm×14cm
2. Machine weight: about 5kg

## Chapter Three Operating Instruction

### 4.1 Front panel and function



Figure 1 Front Panel of JK-XU

Front Panel of JK-XA (without USB flash disk offloading function)

#### 1. Main window

Format of Temperature display window: The user can set it to be the display of a large size font, as shown in figure 2, or the display of a small font, as shown in figure 3;

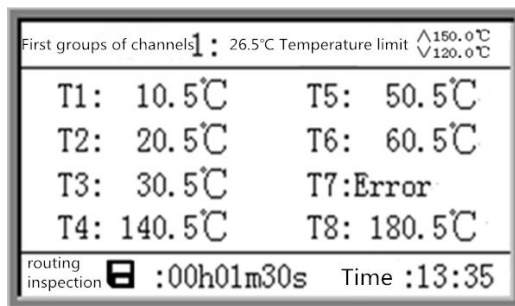

Figure 2 The display of a large size font

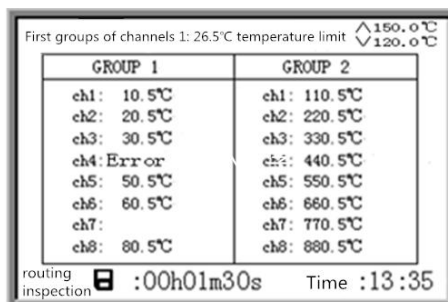

Figure 3 The display of a small font

Explanation of window display:

(1)The first set of channel 1: 26.5℃ temperature limit: This channel is used for highlighting display, convenient for customers to observe some channel, and the temperature limit is the one that this channel uses.

(2)Temperature limit: It is used for highlighting to display channels (including upper limit and lower limit), and it can be used in this channel, the group where this channel is located, or all channels;

(3)The center section shows the temperature value of multiplexer channel, when the large size font displays, what this section displays is the temperature of channel 8 highlighting to display the group where the channel is located; when a small font displays, this section displays multi-group temperature value;

(3)Routing inspection: To display the current status of instrument, it can be routing inspection, fixed point or latch;

(4)  :00h01m30s: it refers to the storage mark and storage time interval, if it is in abnormal storage condition that the instrument is selected for storage and the storage of the instrument is full or USB flash disk is selected for storage, the storage mark displays flickeringly. (JK-XA has no such function)

(5) Time: 13:35 : current time, the storage is also based on this time;

(6)Other instruction:

a, “Over” : Overflow, the temperature value of channel is beyond - 100 °C - 1000 °C, or the surrounding temperature of instrument is beyond -50 - 100 °C, or the thermocouple group is not connected;

b, “Error”: Thermocouple is open;

c, “ ” : Channel is off, the channel or its group is set to “off”. Temperature displays flickeringly: Overrunning, this channel value is beyond the temperature limit.

## 2. Key:

Menu: Selection or validation function;

▼,▲:Up and down option keys are switched to display the content;

◀, ▶: Left and right option keys, “◀” is also used for beginning storage or exiting USB flash disk;

Routing inspection: Use the instrument for routing inspection, to measure each channel’s temperature according to the set channel;

Fixed point: Make the instrument located in the fixed point, to measure the temperature of the highlighted channel;

Latch: Make the instrument keep the display content of the current screen, convenient for the user to observe, only this screen’s display content is latched, but the instrument is still used for storage and measurement normally.

3. Interface of USB flash disk: USB flash disk needs to be connected when U disk or copy instrument are set for storage (JK-XA has no such function)

#### 4.2 Back panel and function

The back panel of the instrument consists of thermocouple interface, RS - 232 - C serial port, power supply socket, fuse block, and etc. Eight groups can be configured at most for the thermocouple input, with eight channels per group. As shown in the figure for the interface drawing of the top two groups, the configured thermocouple is inserted in the interface of thermocouple, and fixed.

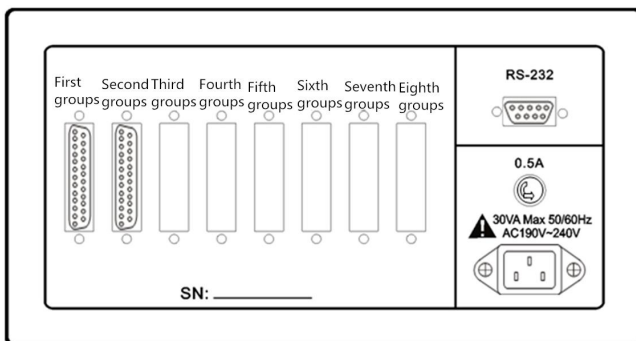

Figure 4 Back Panel

#### 4.3 Operating instructions

(One) Setting the highlighted channel:

Press the key “▶”, the group number or channel number displays flickeringly, use “▼” “▲” to change the channel number, then press the “▶” or when the flicker is stopped after a few seconds exit the setting; The temperature of the current channel is also with flicker in the process of changing the group number or channel Max.

(Two) Switching the display content:

When the large size font displays, change the group number of the highlighted channel, and

you can switch to the other group of temperature display. When a small font displays, in the case of more than 4 groups of configuration, press “▼” “▲” switching to the next screen.

(Three) Operating the menu:

Press “Menu” to enter the setting menu, where you press the direction key to select the item that needs to be set, and press “Menu” to enter the setting of this item, operating each item’s specific setting as follows:

When setting the below submenu, the general function of keys is:

- a, “Menu”: Confirm to select this item or confirm the set parameters of this item;
- b, ◀, ▶: Choose the setting item (it displays flickeringly);
- c, ▼, ▲: Change the parameters of the setting item.

The same item’s function in the submenu of each item is, without otherwise description in each setting:

- a, “Confirmation” : After changing parameters, you can save the setting value only by selecting the “confirmation”;
- b, “return” : Return to the previous menu;
- c, “Exit” : Exit the settings, returning to the display window of temperature;
- d, : Select this item or this item becomes effective;
- e,  : This item is unselected or this item doesn’t work;
- f, Flicker display: It shows this item is the item to be set, if this item has subordinate set items, press “Menu” to enter the setting of its sun-item; If this item has no setting items, to press “Menu” will select the next setting item.

1.Group and channel switch:

(1)Group 1: Use up and down keys to select the group, press “Menu” to enter the switch that sets this group, and use up and down keys to set the switch, press “Menu” returning to the previous menu;

(2)Channel: To show the condition of the channel switch in the current group, press “Menu” to enter the setting of channel switch, use left and right keys to select channels, and use up and down keys to set the switch, press “Menu” returning to the previous menu.

2.Upper and lower limit of the temperature:

8 eight temperature limits can be set at most, and they are used in different channels respectively; but every temperature limit has including and covering function, for example: if the temperature limit 1 is used in channel 1 of group 1, and the temperature limit 3 is used in group 1 or all of the channel, the temperature limit 3 will be selected for the channel 1 of group 1 and the temperature limit 1 won't work.

(1)Temperature limit 1: Use up and down keys to change the temperature limit number, press “Menu” to enter the switch that sets this temperature limit, and use up and down keys to set the switch, press “Menu” returning to the previous menu;

(2)Applied range: Press “Menu” to enter selecting the application range:  all channels/ channel 1 of group 1, use up and down keys to select the application range, if you select  the channel 1 of group 1, press “Menu” to enter setting which group and which channel, use left and right to switch the group or channel setting, use up and down keys to select which group or which channel; if you set to “ channel 1 group 1”, it means this temperature limit is used in all channels of group 1; Press “Menu” returning to the previous menu;

(3)Upper limit, lower limit: Press “Menu” to enter setting the numerical value of the temperature limit, use left and right keys to select bit that needs to be changed, and use up and down keys to change the numerical value of this bit. The upper limit of the temperature should be greater than the lower limit, otherwise it will prompt “Setting fails”.

### 3. Storage setting:

(1)Storage selection:  storage shows to open the storage;

(1)Storage type: Use up and down keys to select the storage type, and the percentage after the instrument storage is the storage space of the used instrument;

(2)Interval: The storage time interval can be set to 9 hours 59 minutes and 59 seconds at most; Press “Menu” to enter the setting of the time interval, and press the direction key to modify the numerical value; The interval of the routing inspection is  $N \times 1.5s$  at least, N is the configuration class number; The interval of the fixed point is 1s at least.

(3)Attention:(JK-XA has no such function)

a, During using USB flash disk for storage, if you want to take down USB flash disk, press “◀” firstly to exit USB flash disk, or part of the data may be lost;

b, Each time using instrument to start storage, the instrument will delete the last stored content, to prevent the data from loss, please export the last stored content through the “Copy instrument storage”;

- c, In the storage state, if the storage condition changes, the instrument will log off the storage state, and the storage mark and the storage time interval will no longer display;
- d, USB flash disk can store 99 documents at most, the instrument can store about  $16\text{ k} \times \text{N}$  temperature values (N is the configuration class number);
- e, The documents in USB flash disk dish should not be excessive, otherwise it may lead to an abnormal storage, but formatting U disk will eliminate the abnormality.

#### 4.The storage of copy instrument:

It is used for copying the content that the instrument stores to USB flash disk, the content format is the same as the storage format of USB flash disk.

In the main menu, select “Copy instrument storage” , and press “Menu” to start copying, if USB flash disk is not connected or you can’t copy normally due to other reasons, the window will display “ Copying fails!”, if you can copy normally, it will display the copying progress, and after completion the window will display “Copying succeeds!”; You can press “Menu” to stop copying in the process of copying.

#### 5.Font selection:

The small font can display multi-group temperature values, but the large size font can only display the temperature value of the channel in this group. As shown in the figure of the previous chapter, you can select large size and small fonts, use up and down keys to select fonts, and use left and right keys to switch the options.

#### 6. Exit:

Press “Menu” to exit the setting menu, returning to the display window of temperature.

#### 7, Thermocouple type:

8 groups can be configured for the model JK-8U at most, the thermocouple type of each group can be different, you can select the thermocouple of model K, J, T, and the thermocouple type of the unconfigured group shows “-”.

Use left and right keys to select setting the thermocouple of which group, use up and down keys to change the thermocouple type of the selected group, press “Menu” pointing to “Confirmation”, left and right keys can return to select the thermocouple type.

#### 8, Thermocouple test:

Select the “Thermocouple test” from the main menu, and press “Menu” to begin testing, it will show the test result after testing, for example:

3 errors detected
GROUP1: 1, 2,
GROUP3: 2,

It shows that the thermocouple of channel 1, 2 of group 1 and channel 2 of group 3 is disconnected.

9, Baud rate:

The baud rate needs to be set in accordance with the baud rate that the upper computer software supports;

For model JK-XU, 4 baud rates can be selected: 2400bps, 4800bps, 9600bps and 19200bps; use up and down keys to select the baud rate, and use left and right keys to select other items.

10, Thermometric scale selection

Use up and down keys to select Celsius temperature scale / Fahrenheit scale, and use left and right keys to select other items.

11, Time setting:

Use up and down keys to select the setting item; press “Menu” to enter the setting item, use left and right keys to select bit, and use up and down keys to modify the select bit; press “Menu” returning to the previous menu.

12, Instrument commissioning:

Instruction: This item is used for setting the relevant parameters when the instrument is produced, and the user can not change its parameter values, otherwise it will cause the instrument can't operate normally.

Select the “Instrument commissioning” from the main menu, press the key “Menu” 4 times, the instrument will prompt “Password is incorrect!”, and return to the main menu.

## 4.4 Cautions

- 1, If the measurement of individual channel is abnormal, you can test whether the thermocouple is open by the instrument.
- 2, In theory the operating ambient temperature of instrument should not be more than -50 – 100°C, otherwise it will prompt “Over”, and the actual operating temperature should not be more than -20 – 70°C.
- 3, At the back of the instrument, there should not be the heat source that the temperature changes frequently, otherwise it maybe cause the measurement is inaccurate.
- 4, The heat resisting thermocouple needs to be configured when the temperature of the measurement point is too high.
- 5, The highest potential difference between thermocouples should not be more than 300V (the true effective value).

## Software instruction

### 5.1 System requirement:

- 1, The operating system is Chinese Windows9x/2000 or other upgraded versions;
- 2, The free space of the hard disk should be more than 2M;
- 3, The display resolution should be in 800x600 and above; we suggest using 1024x768.

### 5.2 Installation

Insert the optical disk which is labeled with “JK-XU Verx.y” (x.y refers to the version number, this software is 1.0, and the baud rate is 2400) into the optical disk drive, double click the JK-XUVerx.y.exe in the optical disk, it will show the dialog box as follows. According to the prompt message, press “Next step” until finishing the installation.

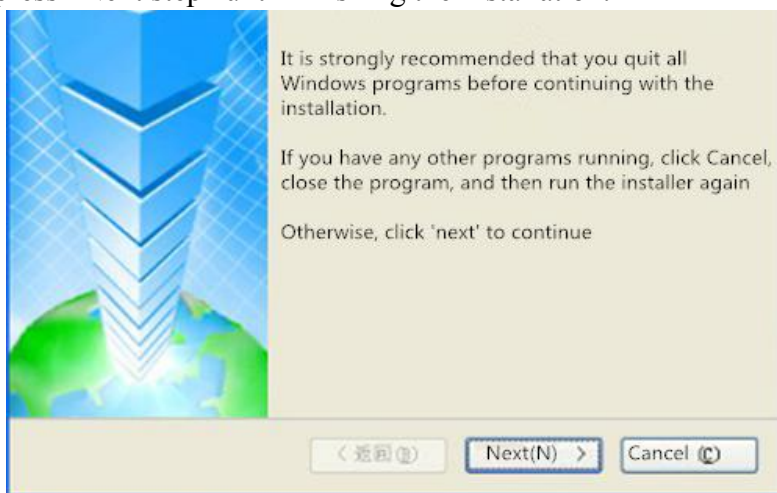

### 5.3 Using and operation

Instruction: JK-XU multichannel temperature patrol-check device software applies to our company's JK-XA electronic ballast multichannel temperature patrol-check device and JK-XU multichannel temperature tester. Thereinto, the model -8 is the temperature of 8 channels, the model -16 is the temperature of 16 channels, and the class number can be prepared for -X in accordance with the user needs. The maximum is 64 channels.

Special statement: This software supports the baud rate setting, the baud rate needs to be set in accordance with the baud rate that the upper computer software supports; For model JK-XU, 4 baud rates can be selected: 2400bps, 4800bps, 9600bps and 19200bps; use up and down keys to select the baud rate, and use left and right keys to select other items.

### 5.3.1 Description of the main menu

The relevant testing icon in the toolbar is shown in figure (3)



Figure (2) Relevant testing icon

From left to right, they are respectively: Create a new file, Open a file, Store the file into USB flash disk; Test, Pause the test, Continue the test; System setting, Product identification; Data or curve displaying; Print, Print preview; and Help. There are corresponding menu options respectively in the menu bar.

### 5.3.2 Description of the main interface

After opening the software, the system shows the interface as shown in figure (3).

- ① Menu bar: It includes File, Setting , Help and other menu items.
- ② Toolbar: It has New, Open, Save, Start, Pause, Continue, Setting, Identification, Print and other press-buttons.
- ③ Identifier: Channel, Identification, Temperature, and Displacement.
- ④ Channel and grouping selection: Select the corresponding checkbox, it will shows the temperature curve of all channels or subchannels in this group.
- ⑤ Grouping name: To display the grouping name, click to open or fold.
- ⑥ Channel identification: You can modify the channel identification directly through continuously clicking twice.
- ⑦ Colour selection: Select the colour of the channel temperature curve, and the setting dialog box will pop out after double-click.
- ⑧ Temperature value: It displays the current temperature of each channel, and it can display the corresponding temperature value through adjusting the scroll bar.
- ⑨ Offset: The vertical offset of each channel can be modified through continuously clicking twice, of which the vertical coordinate is the zero temperature value plus the offset, and you can check the curve of each channel's temperature change with the fixed point.
- ⑩ Grouping and folding: Open or fold each grouping channel.
- (11) Slider: It's used for translating the display area.
- (12)All selection: Select all channels.
- (13)Time: Displaying the current time, it can display the current testing time through moving the scroll bar; But it is worth noting that, in the range beyond the testing curve, it displays the recent

testing time when doing the test, but the temperature value displays the current testing temperature value; It displays the last testing time and the final temperature value after the test is completed.

- (14) Time shaft indexing: Adjusting the transverse magnification of the curve, it can be adjusted from 1 second / grid to 100 hours / grid.
- (15) Temperature shaft indexing: Adjusting the longitudinal magnification of the curve, it can be adjusted from 0.1 Celsius / grid to 35 Celsius / grid.
- (16) Overall offset: Use the curve to overall offset up and down.
- (17) Application: Apply this setting.
- (18) Scroll bar: It is used for translating the time shaft of the graphic area.
- (19) Graphic area: It is used for describing the curve of temperature change, the vertical coordinate refers to the temperature, and the horizontal ordinate refers to the time.

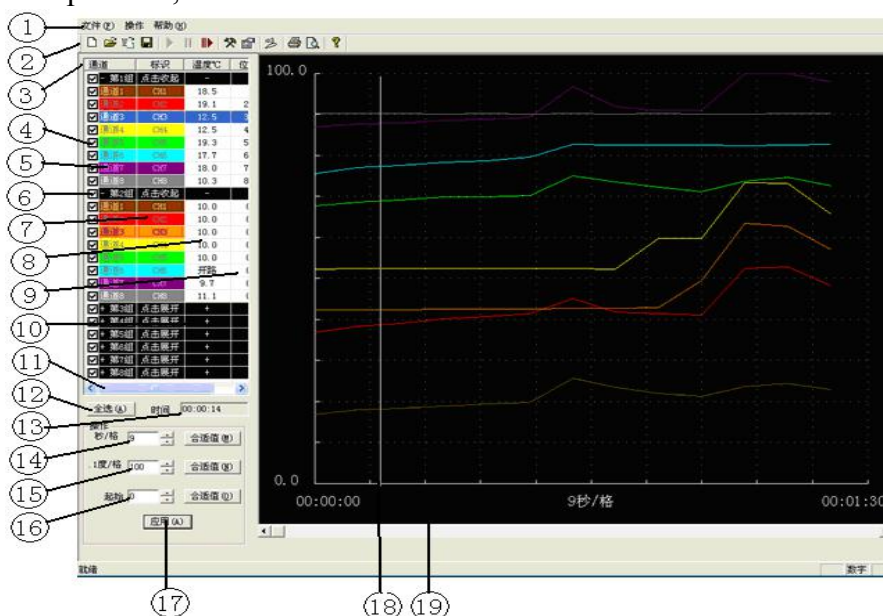

Figure (3) Main Interface

### 5.3.3 Data display

Clicking the “Curve or data display”  press-button in the toolbar, it the testing data window will pop up as shown in the below figure.

Figure (4) Data Display

### 5.3.4 Setting of channel colour

序号	时间	CH1	CH2	CH3	CH4	CH5	CH6	CH7	CH8
0	00:00:00	16.9	16.9	12.4	12.4	17.7	15.7	17.0	10.4
1	00:00:07	18.0	18.4	12.4	12.5	18.7	17.2	17.7	10.3
2	00:00:14	18.5	19.1	12.5	12.5	19.3	17.7	18.0	10.3
3	00:00:21	19.0	20.3	12.6	12.5	19.9	18.5	18.6	10.2
4	00:00:28	19.5	20.9	12.6	12.5	20.0	18.8	18.8	10.3
5	00:00:35	19.9	21.5	12.6	12.5	20.4	19.7	19.5	10.2
6	00:00:42	25.7	25.2	12.8	12.5	25.1	22.8	26.9	10.3
7	00:00:49	23.6	21.9	12.9	12.4	23.6	22.6	21.9	10.2
8	00:00:56	22.1	21.5	13.1	19.8	22.4	22.6	21.0	10.3

Setting the display colour of each channel: Double clicking the channel that needs to change, the dialog box will pop up as shown in figure, then you can select a suitable colour and press the confirmation key.

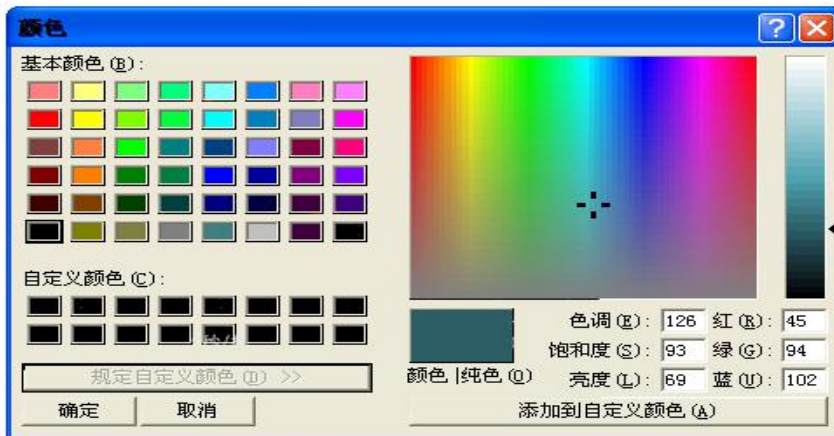



Figure (4) Colour Setting

### 5.3.5 System setting

Click “Operation / System setting” in the menu bar or directly click the press-button  in the toolbar. A dialog box will pop up as shown in figure (5), and you can set each parameter.

#### Operating instructions

a) Communication setting: Selecting the instrument model and communication port, you can set the model, class number and port by “Search” or manually.

b) Setting of sampling and saving

1, Sampling interval means that the software collects the data through communicating with the instrument one time at regular intervals, generally it depends on the selected sampling channel number and actual situation, and the sampling interval should increase one second if one more channel is selected.

2, Auto-save interval: Please save the file immediately after each measure starts, and the system will autosave the test data once according to the set time interval.

3, Hold time: The total time of this test.

c) Setting of printing information: You can set the colour printing, print the page header and the channel identification.

d) Setting of sampling channel: Selecting the channel of this group and selecting the channel, the instrument will sample the temperature of this channel, otherwise it won't sample.

Read the sampling channel from the instrument: Access the automatic reading instrument to the channel.

Write the sampling channel into the instrument: Write the set sampling channel into the

instrument.

e)Confirmation button: Save the set parameters and exit the setting; Cancel button without saving the modification and exit the setting.

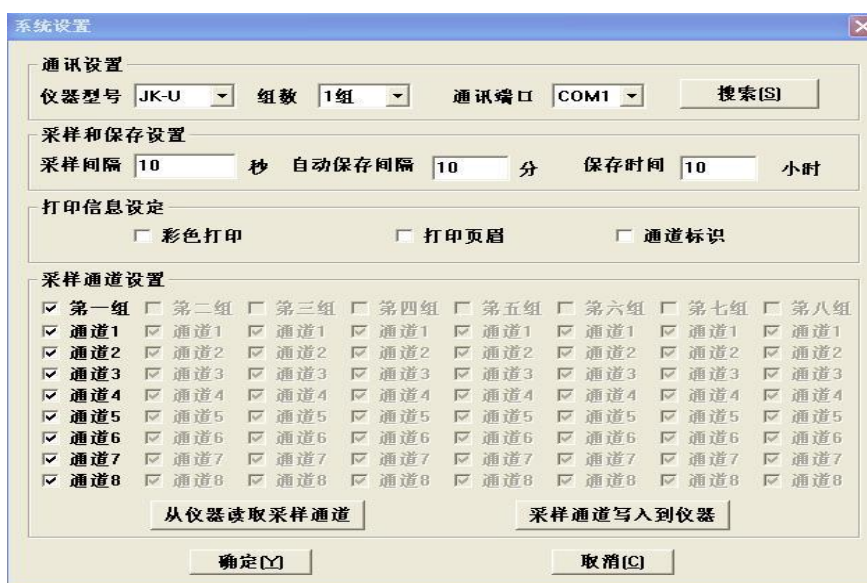



Figure (5) System Setting

### 5.3.6 Product identification setting

1, Enter: From “Operation” of the menu bar – “product identification” or clicking the press-button  in the toolbar, open the dialog box as follows.

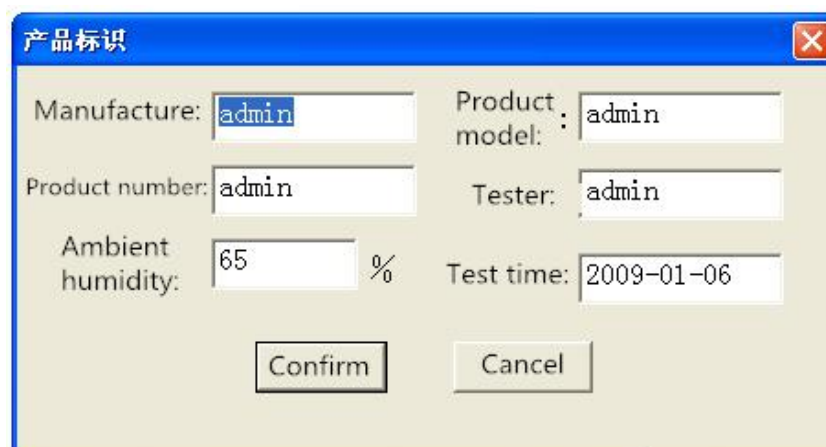





Figure (6) Product Identification Setting

### 5.3.7 Test operation

1, Start test: Start communication from “Operation” of menu bar – “Start test ” or clicking the icon  in the toolbar.

2, Pause communication: Pause communication from “Operation” of menu bar – “Pause test” or clicking the icon  in the toolbar.

3, Continue communication: Continue communication from “Operation” of menu bar – “Continue test” or clicking the icon  in the toolbar.

### 5.3.8 File operation

1, Create a new file: Create a new testfile from “File” of menu bar – “New” or clicking the icon  in the toolbar.

2, Open a file: open a existing testing data file from “File” of menu bar – “Open...” or clicking the icon  in the toolbar.

3, Save the file: Save the test data into the file from “File” of menu bar– “Save...” or clicking the icon  in the toolbar.

Save the file as EXCEL file: You can save the test data in the format of EXCEL file, in order to do the data analysis in EXCEL.

4, Store the file into USB flash disk: Set its path from “File” of menu bar – “Store the file into USB flash disk” or clicking the icon  in the toolbar. (JK-XA has no such function)

5, Printing setup: Open the dialog box of printing setup from “File” of menu bar – “Printing setup”, and you can choose longitudinal or transverse printing in the “Direction” bar.

6, Printing: Print the curve or data of the test temperature from “File” of menu bar – “Printing”. If the current screen shows the curve, you will print the curve, and if it shows the data, you will print the data. In order to print the temperature curve clearly, please choose a suitable printing channel and interval between vertical and horizontal coordinates firstly before printing, and you can use the printing preview function.

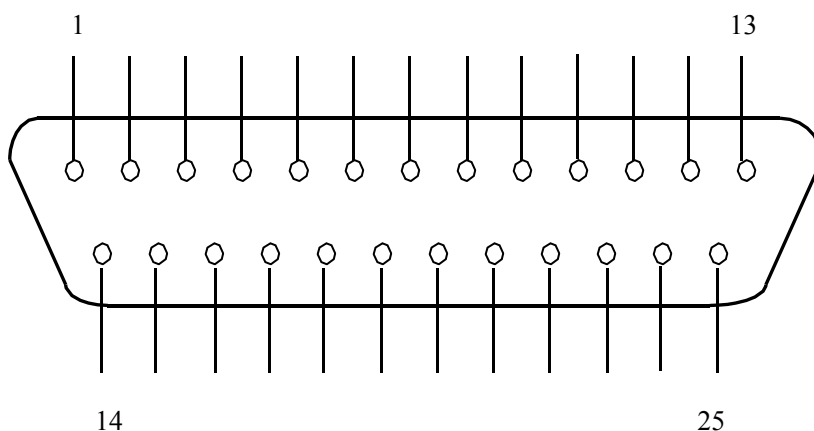

The Schematic Diagram of Temperature Testing Cassete Interface Pins

In the above diagram, the meaning of each pin is as follows:

	Name	Function
1	3 and 16	Sampling resistance
2	4 and 17	Thermocouple of 8 channels, the red line of galvanic couple is welded with the 4th foot
3	5 and 18	Thermocouple of 7 channels, the red line of galvanic couple is welded with the 5th foot
4	6 and 19	Thermocouple of 6 channels, the red line of galvanic couple is welded with the 6th foot
5	7 and 20	Thermocouple of 5 channels, the red line of galvanic couple is welded with the 7th foot
6	8 and 21	Thermocouple of 4 channels, the red line of galvanic couple is welded in the 8th foot
7	9 and 22	Thermocouple of 3 channels, the red line of galvanic couple is welded with the 9th foot
8	10 and 23	Thermocouple of 2 channels, the red line of galvanic couple is welded with the 10th foot
9	11 and 24	Thermocouple of 1 channel, the red line of galvanic couple is welded with the 11th foot

Pay attention it cannot be anti-connected, without cold solder joint.